

Pegler ProFlow





contents

| | |
|---|-----------|
| Aalberts integrated piping systems | 4 |
| Pegler ProFlow | 8 |
| technical data | 13 |
| static applications | 14 |
| dynamic applications | 15 |
| applications | 16 |
| technical characteristics | 17 |
| installation guidelines | 18 |
| Pegler ProFlow BC3 balancing computer | 28 |
| how to use tables and charts | 30 |
| warranty | 36 |
| product range | 37 |
| Pegler ProFlow balancing valves | 37 |
| tools and accessories | 61 |

Aalberts integrated piping systems

don't just buy
products,
buy solutions.



piping technology

we are Aalberts integrated piping systems

Aalberts integrated piping systems engineers the most advanced integrated piping systems for the distribution and control of liquids and gases for key verticals, like industrial, utilities, commercial and residential. We offer fully integrated piping systems in valve, connection, fastening and piping technology. We work hand-in-hand with our customers to create the perfect integrated piping system that meets their requirements. Our piping systems are easy to specify, install, control and maintain, saving important preparation and installation time. We meet the highest quality and industry standards needed in the selected verticals. We are the only business that truly offers its customers a single sourced and complete integrated piping solution, each and every time.

Don't just buy products, buy solutions.

our mission

With our integrated piping systems, supported by our unique Digital Design Service, we ensure that you will always get the best and easiest solution for the installation of an integrated piping system. From the moment that your plan is designed, you can get advice on complete and tailored solutions. With our Revit Plug-in, you have digital access to the complete product offering within Aalberts integrated piping systems. This information is always accessible and up to date, allowing the design of an optimal and economically attractive installation that will meet all your demands. So whether the task is project conception, installation, or on-going maintenance, we are the company that truly delivers a complete system and service offering. Our know-how, our can-do attitude, and our relentless innovation come as standard. We will sweat the small stuff in our quest to find the perfect solutions, even if we have to invent them.

This is how we deliver excellence.

our way of working

We operate from various regions around the globe: America, United Kingdom, Middle East, Asia Pacific and Europe. As we have multiple locations in many countries, we are always close to our customers. More than 3500 mission critical employees are persistent to offer the best integrated piping system. They work on our products, solutions and services every day. No matter how big the opportunity is, when we say we've got this, we won't let go until there is nothing left to learn. We improve ourselves by exchanging knowledge and experience to stay ahead of our competitors.

Good is never good enough.

With our sustainable spirit, we contribute to circularity every single day. This belief is strongly linked to the way we do business. Rethink, reduce and recycle. We are entrepreneurial and take ownership in everything we do. We are convinced that self-development and diversity are essential.

The Aalberts way, winning with people.

the strength of Aalberts integrated piping systems

- the perfect solution for every project
- smart, fast and efficient installation
- valuable advice from the drawing board to delivery
- a very wide product range

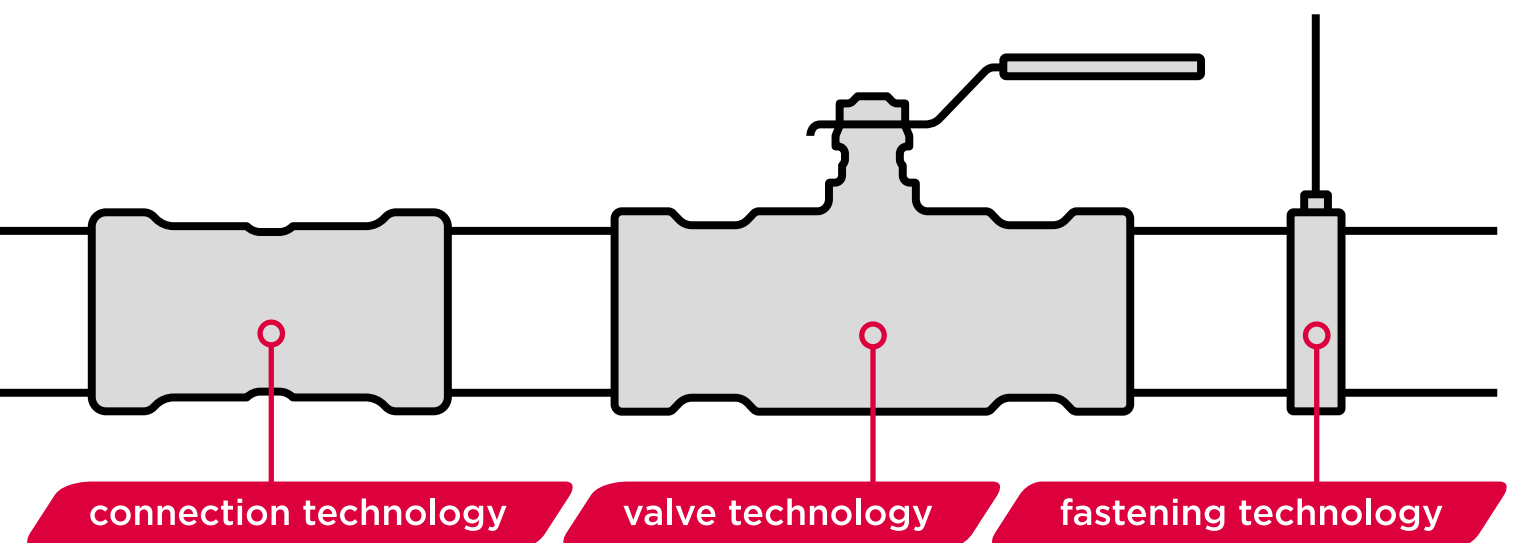

our product lines

Aalberts integrated piping systems is the combination of different companies with individual, well-known brands. Together they offer the best integrated piping system for now and in the future.

connection technology

VSH delivers piping systems throughout the world for over 90 years. In the 1970's VSH brought the well-known VSH Super compression fitting on the market. Nowadays the range consists of various press, compression and push systems for thin and thick walled metal as well as plastic.

Shurjoint history dates back to 1974 when they produced their first grooved couplings, produced from malleable iron. Shurjoint is

recognized as a world leader in the design and manufacture of mechanical piping components.

valve technology

Pegler is a globally respected brand known for high-quality plumbing, heating, and engineering products. Since the 1890s, its reputation has been built on innovation, quality and strong customer service. Today, Pegler is still a key player in the valve industry, continuously designing new valve solutions.

fastening technology

The **FastFix** fastening range consists of brackets, rails and accessories for secure

We offer product ranges that:

- connect seamlessly
- are available in dimensions from 6 mm up to 104" (DN2600)
- can be used for thick-walled pipe and thin-walled metal or plastic tube
- have press, compression, groove and push connections
- can be expanded with valves and accessories

and efficient mounting. Designed for practical use across various applications, our products combine reliability with ease of installation. Whether for industrial setups or everyday solutions, we help you build with confidence.

VSH CoolPress



new!

| | |
|--------------|--------------------------|
| material | copper |
| suitable for | copper |
| connection | press / specific profile |
| dimensions | ¼" - 1½" |

FastFix



new!

| | |
|--------------|---|
| material | mild carbon steel / stainless steel |
| finishes | zinc plated / hot dip galvanised |
| suitable for | all types of piping systems |
| connection | 10 - 406 mm (¼" - 16") |
| options | with or without sound-absorbing insert & thermal insulation |

Kuterlite



| | |
|--------------|---|
| material | brass |
| suitable for | carbon steel / stainless steel / copper / plastic |
| connection | compression |
| dimensions | 6 - 54 mm (DN4 - DN50) |

VSH Shurjoint



| | |
|--------------|---|
| material | ductile iron / stainless steel |
| suitable for | thick-walled steel / stainless steel / HDPE |
| connection | groove |
| dimensions | ½" - 104" (DN15 - DN2600) |

Pegler Valves



| | |
|--------------|---|
| material | brass / bronze / DZR brass / ductile iron / stainless steel |
| suitable for | carbon steel / stainless steel / copper / plastic |
| connection | threaded / press / push / flange |
| dimensions | ½" - 12" (DN15 - DN300) |

Pegler ProFlow



| | |
|--------------|---|
| material | brass / ductile iron |
| suitable for | carbon steel / stainless steel / copper / plastic |
| connection | threaded / press / flange |
| dimensions | ½" - 12" (DN15 - DN300) |

VSH XPress



| | |
|--------------|--|
| material | carbon steel / stainless steel / copper / CuNiFe |
| suitable for | carbon steel / stainless steel / copper / CuNiFe |
| connection | press / M-profile |
| dimensions | 12 - 108 mm (DN10 - DN100) |

VSH Tectite



| | |
|--------------|---|
| material | copper / brass / stainless steel |
| suitable for | copper / carbon steel / stainless steel |
| connection | push |
| dimensions | 10 - 54 mm (DN8 - DN50) |

VSH PowerPress



| | |
|--------------|-----------------------|
| material | carbon steel |
| suitable for | thick-walled steel |
| connection | press / DW-profile |
| dimensions | ½" - 2" (DN15 - DN50) |

VSH UltraPress



| | |
|--------------|--------------------------|
| material | PPSU / brass |
| suitable for | plastic |
| connection | press / U & TH profile |
| dimensions | 14 - 63 mm (DN10 - DN50) |

Endex



| | |
|--------------|-------------------------------|
| material | copper / gunmetal / DZR brass |
| suitable for | copper |
| connection | solder |
| dimensions | 6 - 54 mm |

Yorkshire



| | |
|--------------|------------------------|
| material | copper / copper alloy |
| suitable for | copper |
| connection | integrated solder ring |
| dimensions | DN15 - DN300 |

Pegler Prestex



| | |
|--------------|---|
| material | brass / DZR brass |
| suitable for | carbon steel / stainless steel / copper / plastic |
| connection | threaded / press / push / flange |
| dimensions | ½" - 12" (DN15 - DN300) |

Pegler Radiator Valves



Bulldog

Terrier

Belmont

Mistral

| | |
|--------------|-----------------------------------|
| material | brass / gunmetal |
| suitable for | iron / copper / plastic |
| connection | compression / threaded / push-fit |
| dimensions | 8, 10, 15, 20 mm, ½", ¾" & 1" |

Pegler ProFlow

The Pegler ProFlow valve range offers installers a comprehensive commercial and balancing valve solution. Pegler ProFlow valves are manufactured in the UK at the Aalberts integrated piping system facility using the latest manufacturing processes, including the use of extruded material such as low-lead DZR Brass.

Our end-to-end process provides continuity of British manufacturing and testing, ensuring the highest level of reliability and quality. Our complete range of balancing valve technology, and expertise, ensure the accuracy, flexibility and system efficiency essential to building applications.



static balancing valves

The Pegler ProFlow 1260 fixed orifice series of valves provides isolation and balancing of piping systems and equipment, in both HVAC and general plumbing applications.

Each valve can be double regulated, closed and then reopened to a selected value, which can be set on commissioning. Additionally, the Pegler ProFlow 1260 series incorporates a measuring facility, and the flow rate can be verified using the Pegler ProFlow BC3 balancing computer.

advantages of the Pegler ProFlow static valves

1260 and V955

- DZR brass body with all threaded valves rated to 20 bar, and VSH XPress valves rated to 16 bar
- handwheel incorporating position indicator with double regulating feature on spindle
- $\pm 5\%$ flow measurement accuracy across all setting points
- threaded connection. Also available pre-adapted using VSH XPress and VSH PowerPress technology, facilitating heat free connections
- suitable for heating and cooling applications
- robust handle manufactured from tough, glass-reinforced polymer
- memory stop
- DN65 - DN300 flanged versions also available (V955 series)



dynamic balancing valves

The revolutionary Pegler ProFlow 1600 PICV (Pressure Independent Control Valve) comes complete with integrated bypass technology. This industry-leading innovation provides significant time and cost savings, with the use of a full velocity bypass making the installation, commissioning and maintenance process simple. The Pegler ProFlow 1600 PICV adds advanced functionality to control and accuracy. The differential pressure loss can be verified using the Pegler ProFlow BC3 balancing computer.

The new Pegler ProFlow 1500 is a great addition to the PICV family. With a range flexibility of DN15 to DN50, the new 1500 PICV comes complete with a direct fast flush cap giving simple access to removing the cartridge. The location of test points allow direct flow measuring utilising the built in venturi technology.

Both direct flow rates and differential pressure loss can be verified using the Pegler ProFlow BC3 balancing computer.

advantages of the Pegler ProFlow dynamic valves

1600 PICV

- DZR brass body with all threaded valves and VSH XPress valves rated to 16 bar
- removes potential of cartridge mix-up issues
- ensures bypass/flushing have been actioned to prevent future issues
- can be utilised as isolating valve - no need for ball valve inline
- less time removing cartridges for flushing
- prevents deposit of debris within product
- supports water treatment to meet timescales in accordance with BSRIA guidelines threaded

1500 PICV

- achieves between 2% to 6% flow measurement accuracy across all setting points
- fast measuring with fixed venturi orifice
- easy cartridge exchange
- allows for full-flow flush
- settings visible when the actuator is attached



measuring and control

The Pegler ProFlow BC3 balancing computer is pre-programmed with the required loss coefficient data (Kvs values). This allows a direct measurement of flow rates to be obtained, thereby ensuring the system is balanced correctly to achieve optimum efficiency.



actuation

The Pegler ProFlow Actuation range provide application solutions, including standard on/off thermic actuation to fast acting motoric actuators.

electro thermal actuation - on/off and modulating

Natural convection (passive) terminal units (i.e. passive chilled beams and underfloor heating) are designed to be less responsive to changes in room temperature than forced convection terminal units.

electro-motoric actuation - floating and proportional

Pegler ProFlow electro-motoric actuators can react to flow rate and heat output changes matching demand requirements rapidly, ensuring the perfect solution, suitable for convection terminal applications.



electro thermal actuator

electro motoric actuator

advantages

- simple and accessible interface
- user app for Android / iOS mobile devices
- ability to measure flow and differential pressures accurately
- digital compensation of temperature effects
- correction of antifreeze flow calculation
- easy selection of balancing valve according to valve illustration
- cover IP65 rated

embodied carbon

Measuring our carbon emissions is the first step on the path to reducing them. As manufacturers of integrated piping systems, disclosing the embodied carbon of our products is key for achieving credible full life cycle assessments of the systems and buildings we help build.

The embodied carbon of a product includes all emissions released during making, installing and end-of life disposal. This excludes any emissions produced during its use and any benefits of potential reuse, recovery or recycling of materials at the end of its life. In the case of Aalberts IPS products, most emissions originate from the raw materials used to make them. This report does not include embodied carbon of packaging.

The tables shows the embodied carbon of our products calculated using **CIBSE TM65***. The total embodied carbon is reported in **kgCO₂e**: kg of carbon dioxide equivalents. This shows the impact of all greenhouse gas emissions as if they were CO₂ to allow for unified reporting.

While we conduct further investigation into our supply chains, we are choosing to calculate embodied carbon by using industry average values for the percentage of recycled content in our raw materials.

total embodied carbon 1500 PICV Dynamic balancing valves

| dimension | 1500 article no. | kgCO ₂ e* | PS1500 article no. | kgCO ₂ e* | PSU1500 article no. | kgCO ₂ e* |
|-----------|------------------|----------------------|--------------------|----------------------|---------------------|----------------------|
| DN15 LF | 15112 | 3.28 | 15184 | 3.720 | 15459 | 4.148 |
| DN15 SF | 15113 | 3.278 | 15185 | 3.714 | 15461 | 4.142 |
| DN15 HF | 15114 | 3.271 | 15186 | 3.708 | 15463 | 4.136 |
| DN20 SF | 15115 | 5.214 | 15187 | 5.904 | 15464 | 6.488 |
| DN20 HF | 15116 | 5.234 | 15188 | 5.924 | 15466 | 6.508 |
| DN25 SF | 15117 | 7.983 | 15189 | 9.012 | 15467 | 9.922 |
| DN25 HF | 15118 | 7.982 | 15199 | 8.497 | 15469 | 9.921 |
| DN32 HF | 15119 | 10.193 | 15200 | 11.727 | 15479 | 12.930 |
| DN40 SF | 15272 | 17.879 | 15274 | 20.004 | 15488 | 21.420 |
| DN50 HF | 15273 | 19.854 | 15275 | 23.615 | 15489 | 24.623 |

total embodied carbon 1600 PICV Dynamic balancing valves

| dimension | 1600 article no. | kgCO ₂ e* | PS1600 article no. | kgCO ₂ e* | PSU1600 article no. | kgCO ₂ e* |
|-----------|------------------|----------------------|--------------------|----------------------|---------------------|----------------------|
| DN15 LF | 16001 | 4.422 | 16020 | 4.858 | 16050 | 5.287 |
| DN15 SF | 16002 | 4.416 | 16021 | 4.853 | 16051 | 5.282 |
| DN15 HF | 16003 | 4.409 | 16022 | 4.846 | 16052 | 5.275 |
| DN20 SF | 16004 | 6.988 | 16023 | 7.678 | 16053 | 8.333 |
| DN20 HF | 16005 | 6.887 | 16024 | 7.579 | 16054 | 8.232 |
| DN25 SF | 16006 | 8.486 | 16025 | 9.515 | 16055 | 10.428 |

* Embodied carbon calculated following 'Basic' calculation method described in CIBSE (2021) Embodied carbon in building services: a calculation methodology CIBSE TM65: 2021 (Hampshire: Hobbs the Printers Ltd) using CIBSE (2022) Embodied Carbon Calculator TM65 Digital Tool betaversion 1.1 January 2022 (London: Chartered Institution of Building Services Engineers)





Pegler ProFlow

technical
data

static applications

fan coil system with two-way motorized valves

The Pegler ProFlow 1260 provides hydronic balancing in variable flow systems in order to ensure that the optimum flow is achieved at all load conditions, in the fan coil units. The actuator controlling the two-way valve is connected to a room thermostat or BMS system. By opening or closing the two-way valve in reference to the room temperature the flow in each fan coil can be controlled, and the required temperature is achieved.

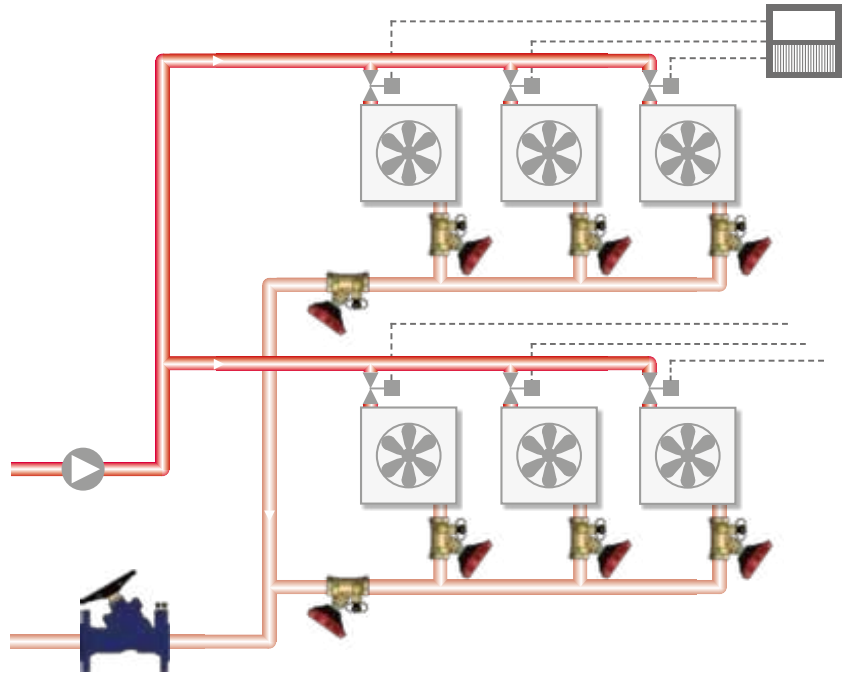

constant flow system

The Pegler ProFlow 1260 provides hydronic balancing in constant flow systems, using a three-way motorized valve, in order to ensure that the optimum flow is achieved for the units, at all load conditions. The Pegler ProFlow ensures that the pressure loss over the terminal unit branch is constant, regardless of the three-way valve position. The actuators controlling the three-way valve are connected to a thermostat or BMS system to control the flow in each unit (fan coil, air heater, radiant panel, etc). By opening or closing the three-way valve in reference to the room temperature, the required temperature is achieved.

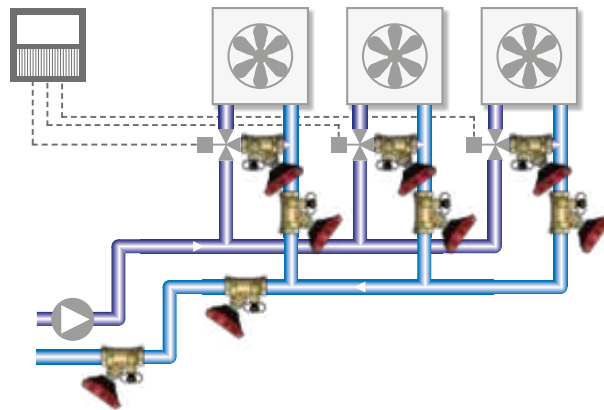

underfloor heating system

The Pegler ProFlow 1260 ensures the required flow distribution to all manifolds in an underfloor heating system. The actuators controlling the two-way valves are connected to a room thermostat or BMS system. By opening or closing the two-way valve in reference to the room temperature the flow in each loop can be controlled, and the required temperature is achieved.

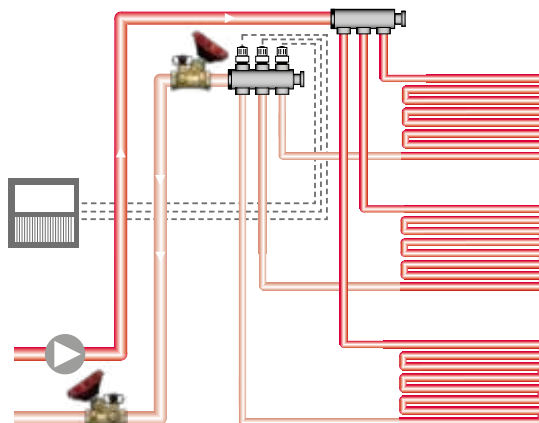

dynamic applications

fan coil system with variable flow

The Pegler ProFlow 1600 or 1500 PICV provides hydronic balancing in variable flow systems in order to ensure the optimum flow is achieved at all load conditions, in the terminal units. The actuator controlling the two-way valve inside the Pegler ProFlow 1600 or 1500 PICV is connected to a room thermostat or a BMS system. By opening or closing the two-way valve in reference to the room temperature, the required temperature is achieved.

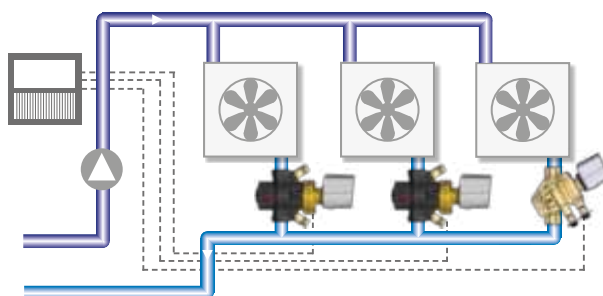

fan coil system with constant flow

The Pegler ProFlow 1600 or 1500 PICV provides hydronic balancing in a constant flow system, equipped with a three-way motorized valve, in order to ensure the optimum flow is achieved at all load conditions, in a fan coil or other terminal unit. In this application temperature control is achieved by the operation of the motorized valve, rather than an actuator, which is connected to a thermostat or BMS system. By the opening or closing of this valve in reference to the room temperature, the required temperature is achieved.

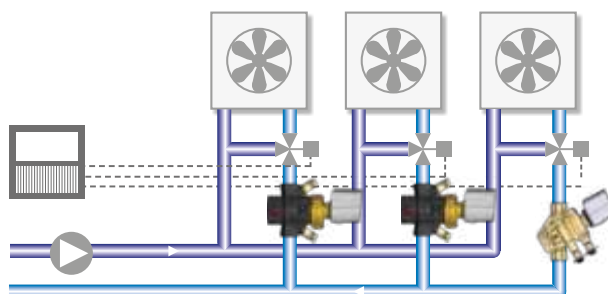

central heating system

The Pegler ProFlow 1600 or 1500 PICV can be installed in a branch of a central heating system with radiators or other terminal units. This ensures that pressure fluctuations from the remaining part of the system will be isolated from the controlled branch, maintaining constant flow. The actuator controlling the two-way valve of the Pegler ProFlow 1600 or 1500 PICV is connected to a thermostat or BMS system. By opening or closing the two-way valve in reference to the room temperature, the required temperature is achieved.

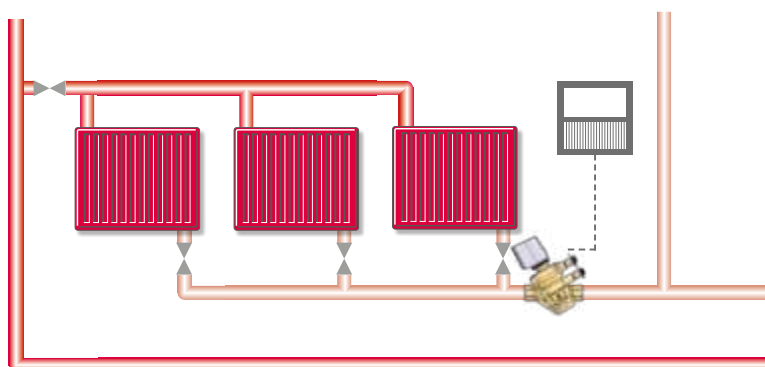

end of line system

The Pegler ProFlow 1600 or 1500 PICV can be used as an end of line valve without the use of an actuator. The Pegler ProFlow 1600 or 1500 PICV can act as a constant flow device to maintain a minimal flow when there is no demand.

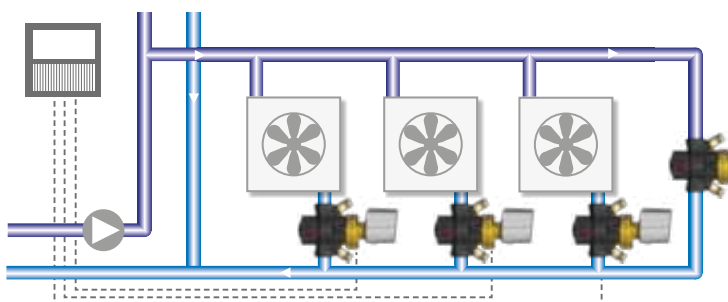

applications



heating installations

Pegler ProFlow Valves are used in heating applications and are suitable for water and other neutral liquids. For media other than water, measuring corrections must be applied

Static balancing

Pegler ProFlow 1260 static balancing valve

| | |
|-------------------------|-----------------|
| connection | female thread |
| operating temperature | -10°C to +120°C |
| max. operating pressure | 20 bar |

Pegler ProFlow PP1260 static balancing valve

| | |
|-------------------------|---------------------------|
| connection | VSH PowerPress connectors |
| operating temperature | -10°C to +120°C |
| max. operating pressure | 16 bar |

Pegler ProFlow PS1260 static balancing valve

| | |
|-------------------------|-----------------------|
| connection | VSH XPress connectors |
| operating temperature | -10°C to +110°C |
| max. operating pressure | 16 bar |

Pegler ProFlow V955 static balancing valve

| | |
|-----------------------|-----------------|
| connection | flange |
| operating temperature | -10°C to +120°C |
| max. pressure | 16 bar |

Dynamic balancing

Pegler ProFlow 1600 PICV

pressure independent control valve

| | |
|-------------------------|----------------|
| connection | female thread |
| operating temperature | -10°C to +90°C |
| max. operating pressure | 16 bar |

Pegler ProFlow PS1600 PICV

pressure independent control valve

| | |
|-------------------------|-----------------------|
| connection | VSH XPress connectors |
| operating temperature | -10°C to +90°C |
| max. operating pressure | 16 bar |

Pegler ProFlow 1500 PICV

pressure independent control valve

| | |
|-------------------------|----------------|
| connection | female thread |
| operating temperature | -10°C to +90°C |
| max. operating pressure | 16 bar |

Pegler ProFlow PS1500 PICV

pressure independent control valve

| | |
|-------------------------|-----------------------|
| connection | VSH XPress connectors |
| operating temperature | -10°C to +90°C |
| max. operating pressure | 16 bar |



cooling installations

Pegler ProFlow Valves are used for cooling applications and suitable for water and other neutral liquids or water with glycol. For media other than water, measuring corrections must be applied

Static balancing

Pegler ProFlow 1260 static balancing valve

| | |
|-------------------------|-----------------|
| connection | female thread |
| operating temperature | -10°C to +120°C |
| max. operating pressure | 20 bar |

Pegler ProFlow PP1260 static balancing valve

| | |
|-------------------------|---------------------------|
| connection | VSH PowerPress connectors |
| operating temperature | -10°C to +120°C |
| max. operating pressure | 16 bar |

Pegler ProFlow PS1260 static balancing valve

| | |
|-------------------------|-----------------------|
| connection | VSH XPress connectors |
| operating temperature | -10°C to +110°C |
| max. operating pressure | 16 bar |

Pegler ProFlow V955 static balancing valve

| | |
|-----------------------|-----------------|
| connection | flange |
| operating temperature | -10°C to +120°C |
| Max. pressure | 16 bar |

Dynamic balancing

Pegler ProFlow 1600 PICV

pressure independent control valve

| | |
|-------------------------|----------------|
| connection | female thread |
| operating temperature | -10°C to +90°C |
| max. operating pressure | 16 bar |

Pegler ProFlow PS1600 PICV

pressure independent control valve

| | |
|-------------------------|-----------------------|
| connection | VSH XPress connectors |
| operating temperature | -10°C to +90°C |
| max. operating pressure | 16 bar |

Pegler ProFlow 1500 PICV

pressure independent control valve

| | |
|-------------------------|----------------|
| connection | female thread |
| operating temperature | -10°C to +90°C |
| max. operating pressure | 16 bar |

Pegler ProFlow PS1500 PICV

pressure independent control valve

| | |
|-------------------------|-----------------------|
| connection | VSH XPress connectors |
| operating temperature | -10°C to +90°C |
| max. operating pressure | 16 bar |

technical characteristics

Pegler ProFlow 1260 FODRV



The Pegler ProFlow 1260 valve is suitable for balancing, pre-set adjusted flow, measurement and flow shut off. The body and valve internals of the Pegler ProFlow 1260 are made of dezincification resistant brass CW511L. The valve seat is made out of

PTFE. The valve has a non-rising stem and handwheel. The handwheel is made from 30% glass filled PA 66 and has a position indication with 80 setpoints. The valve provides a linear flow characteristic and has a memory stop.

The valve is equipped with two self-sealing test points for flow measurement, which are provided with colour coded caps.

markings

marking on valve body: pressure rating (PN) and dimension (DN), flow direction
 marking on handwheel: open/close indicator, setpoint indicator

connections

The valve can be supplied with female threaded connections, VSH XPress connections, VSH PowerPress connections and union connections.

Pegler ProFlow V955 FODRV



The Pegler ProFlow V955 valve is suitable for balancing, pre-set adjusted flow, measurement and flow shut off. The body of the V955 is made of ductile iron EN-GJS-400-15 and the valve internals of the V955 are made of brass and stainless steel. The valve

has a non-rising stem and handwheel. The handwheel is made from steel and has position indication with 8 setpoints. The valve is equipped with two self-sealing test points for flow measurement, which are provided with colour coded caps.

markings

marking on valve body: pressure rating (PN) and dimension (DN), flow direction
 marking on handwheel: open/close indicator, setpoint indicator

connections

The valve is supplied with flanges according to EN1092-2 PN16.

Pegler ProFlow 1600 PICV



The valve is suitable for automatic pressure independent balancing, modulating control, measurement and flow shut off. The body of the Pegler ProFlow 1600 PICV is made of dezincification resistant brass CW511L. The valve internals are made of polyphenylene Sulphide (PPS). The valve is suitable for actuation. The valve has an adjustable a

position indication with 10 setpoints. The valve is equipped with two self-sealing test points for flow measurement, which are provided with colour coded caps.

markings

marking on valve body: pressure rating (PN) and dimension (DN), setpoint indicator, flow
 marking on shuttle: direction symbols for 'flush', 'shut-off' and 'dynamic operation'

connections

The valve can be supplied with female threaded connections, VSH XPress connections, VSH PowerPress connections and union connections.

Pegler ProFlow 1500 PICV



The valve is suitable for automatic pressure independent balancing, modulating control, measurement and flow shut off. The body of the Pegler ProFlow 1500 PICV is made of dezincification resistant brass CW511L. The valve internals are made of

polyphenylene Sulphide (PPS). The valve is suitable for actuation. The valve has an adjustable a position indication with 10 setpoints. The valve is equipped with two self-sealing test points for direct flow measurement, which are provided with colour coded caps.

markings

marking on valve body: pressure rating (PN) and size (DN), setpoint indicator, flow
 markings: direction symbols for 'flush', 'shut-off' and 'dynamic operation'

connections

The valve can be supplied with female threaded connections, VSH XPress connections and VSH PowerPress connections.

installation guidelines

Pegler ProFlow 1260

Unpack the valve and check that the flow paths and valves are clean and free from debris. Check the body markings and nameplate, where fitted, to ensure that the correct valve has been selected for installation.

When correctly providing it is fitted so that the fluid transported follows the indicated flow direction.

Pegler ProFlow valves are manufactured to exacting standards and, therefore, should not be subjected to misuse.

The following should be avoided:

- careless handling of the valve (valves should not be lifted using the hand wheel or the stem)
- dirt and debris entering the valve through the end ports
- excessive force during assembly and hand wheel operation

Use suitable hangers close to both ends of the valve in order to remove stresses transmitted by the pipe. Confirm that the pipe threading length is correct to avoid excessive penetration of the pipe into the valve that would otherwise cause damage.

Care should be taken to apply jointing compound to the pipe only and not in the valve threads. Surplus compound will then be forced outwards and will not enter the valve. Overuse of compound can lead to valve failure on the body ends.

Threads should be engaged correctly when tightening the valve onto the pipe. The wrench should always be fitted on the body end adjacent to the joint being made. Severe damage can occur to stems, valves and seats by the use of hand wheels or levers larger than those originally supplied by the manufacturer, and by wheel keys.

Press-fit valves include the VSH XPress connectors and these are bronze and are suitable for copper, stainless steel and carbon steel tube. The joints are of the leak before press type and utilise the M press profile. Full instructions on press jointing are available in the VSH XPress technical manual.

Pegler ProFlow valves are also available with VSH PowerPress connections, suitable for thick wall steel tube. These connections utilise the DW press profile and are provided with the Leak Before Press function. Full instructions on VSH PowerPress connections are available in the VSH PowerPress technical manual.

mounting

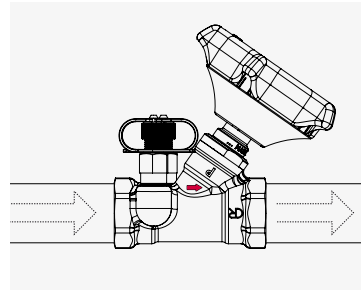

1. an arrow on the Pegler ProFlow 1260 housing indicates the flow direction to be respected.

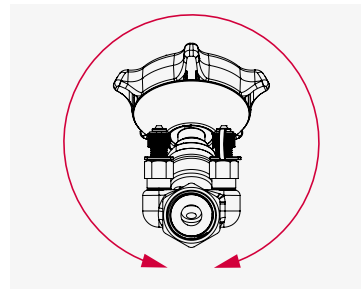

2. the Pegler ProFlow 1260 can be orientated 360° around the pipe axis.

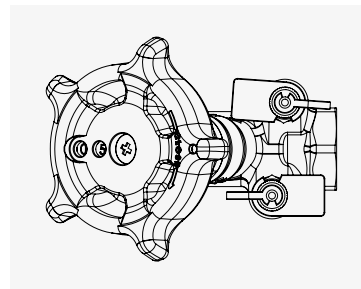

3. no additional space is required for operation of the valve following installation.

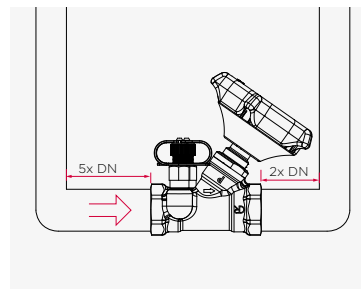

4. 5 x DN straight piping is required before the valve and after any bend and 2 x DN after the valve and before any bend.

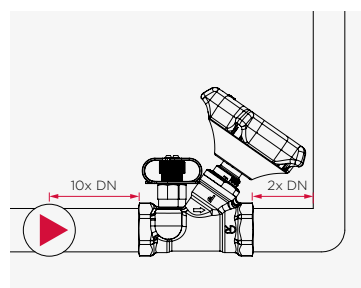

5. 10 x DN straight piping is required when the valve is mounted directly after the system pump and 2 x DN is required after the valve and before any bend.

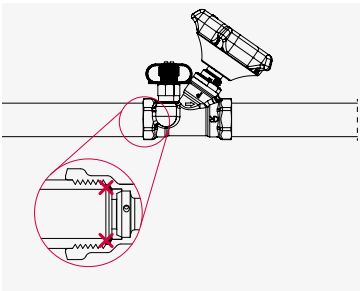

6. loose thread sealant must not hang into the pipe.

8. when installing the Pegler ProFlow PS1260 valves please refer to the VSH XPress technical manual for VSH XPress connection instructions. For Pegler ProFlow PP1260 valves please refer to the VSH PowerPress technical manual for VSH PowerPress connection instructions.

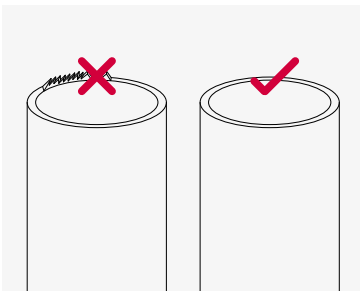

7. deburring of pipe ends is required to prevent system clogging.

valve operation by handwheel

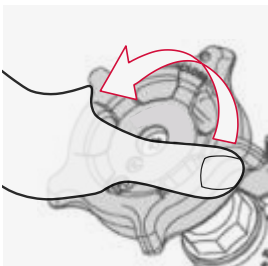

1. Regulation - an anti-clockwise rotation of the handwheel will open the valve. When it will go no further, return the handwheel clockwise $\frac{1}{2}$ turn.

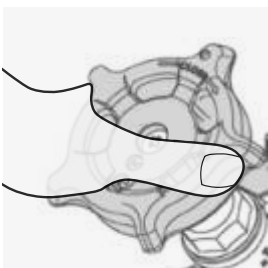

2. when using the Pegler ProFlow 1260, the valve should always be in a fully open position prior to system flushing or commissioning.

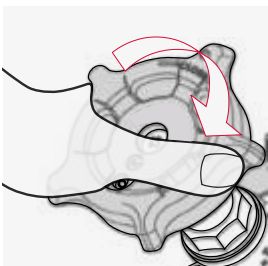

3. to close the valve - a clockwise rotation of the handwheel will close the valve. Closure will be confirmed when the handle can be turned no further.

position and locking settings

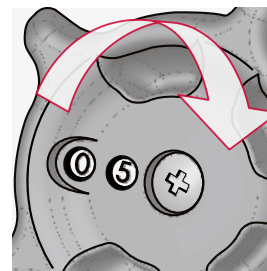

4. Adjust to the desired flow rate, the Pegler ProFlow 1260 valves have a visible position indicator set into the valves handwheel. This allows for regulation positions (00 to 79)

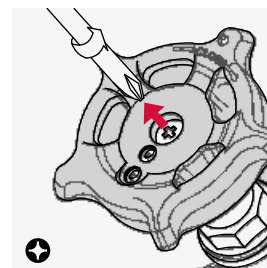

5. remove screw in order to access the allen key socket.

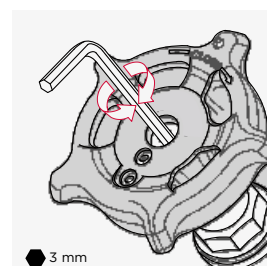

6. use an allen key to secure the mechanism in the handle, this locks the set point position. When the valve is closed in its isolating position the valve can be reopened to the previous set point to avoid further costly commissioning. Then return screw back into position.

Pegler ProFlow V955

Unpack the valve and check that the flow paths and valve are clean and free from debris. Check the body markings and nameplate, where fitted, to ensure that the correct valve has been selected for installation.

Before valve installation the pipe work to which the valve is to be connected should be inspected for cleanliness and freedom from debris. The valve is marked with a directional flow arrow on the body. The valve will function correctly providing it is fitted so that the fluid transported follows the indicated flow direction. Ensure that any flange protectors are removed.

Ensure that the valve is fully open during installation. Flange components have their own design limitations and correct selection and compatibility is vital.

Pegler ProFlow valves are manufactured to exacting standards and, therefore, should not be subjected to misuse. The following should be avoided:

- careless handling of the valve
- dirt and debris entering the valve through the end ports
- excessive force during assembly and operation

flange connection

- pressure and temperature must not exceed its rating.
- gasket selection must be in line with the rating of the flange
- the fluid being handled will affect the gasket selection.
- all bolts must be compatible with the mating flange being used.
- pipe and its mating flange should be cleaned and made ready for assembly.
- a clean and appropriate gasket should be selected for the flange type being used.
- flat face and raised faces flanges should not be mixed.
- piping should be properly supported with the use of correctly sized hanging or securing brackets.
- all pipes need to be aligned correctly to ensure that the valve integrity is maintained, avoiding twisting and distortion of the valves structure and valve damage.
- as the valve is assembled in the pipeline ensure that the bolts are placed and secured with nuts at hand tightness employing the crossover method of tightening to secure a sound and leak tight joint.
- double regulating balancing valves provide positive shut off but when installing the valve respect for the flow direction must be made as indicated by the body arrow.
- use suitable hangers close to both ends of the valve in order to remove stresses transmitted by the pipe.

mounting

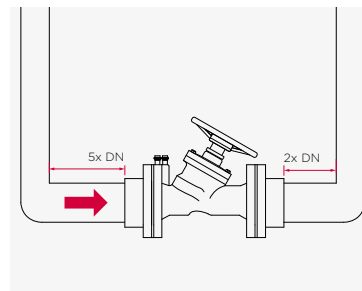
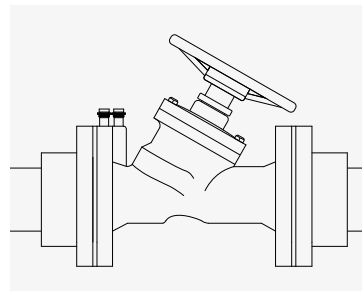
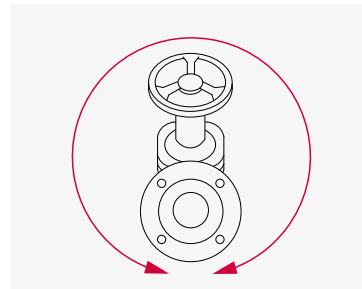
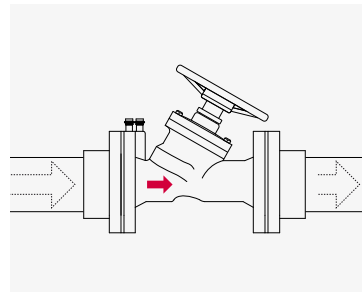

1. an arrow on the Pegler ProFlow V955 housing indicates the flow direction to be respected.

2. the Pegler ProFlow V955 can be orientated 360° around the pipe axis.

3. no additional space is required for operation of the valve following installation.

4. 5 x DN straight piping is required before the valve and after any bend and 2 x DN after the valve and before any bend.

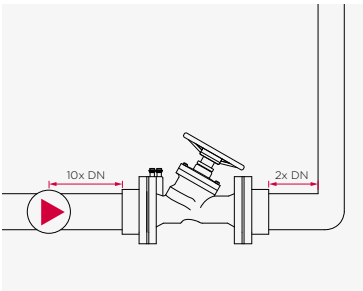

5. 10 x DN straight piping is required when the valve is mounted directly after the system pump and 2 x DN is required after the valve and before any bend.

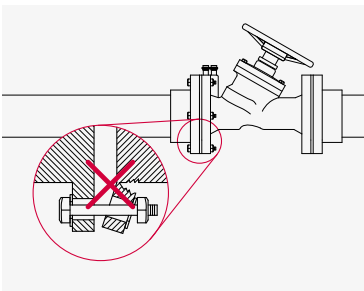

6. it is important to ensure that flange faces are seated against each other before tightening, use of the flange bolts to pull the two faces together can result in damaged flanges.

operation

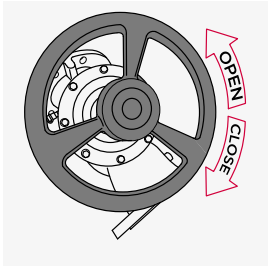

1. **to open** - an anti clockwise rotation of the hand wheel will open the valve. When it will go no further then rotate the hand wheel clockwise a 1/2 turn.
to close - a clockwise turn of the hand wheel. Closure will be confirmed when the handle can be turned no further.

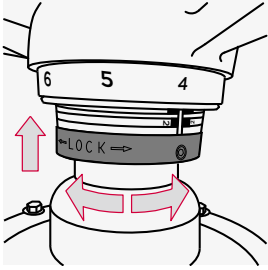

3. adjust to the desired flow rate, Then lift up the collar and align to cross section.

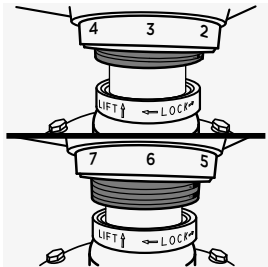

2. regulating positions are readable on the scale counter on the valve stem as the valve handle is turned to achieve a set flow rate. Suitable hand protection should be worn when operating valves used in extreme temperature applications.

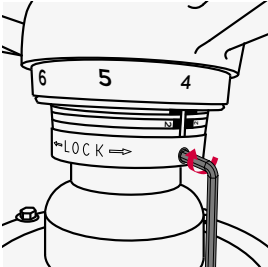

4. simply tighten the collar using an allen key, The Pegler ProFlow V955 will be locked in position.

Pegler ProFlow 1600 PICV

Unpack the valve and check that the flow paths and valve threads are clean and free from debris. Check the body markings and nameplate, where fitted, to ensure that the correct valve has been selected for installation.

Before valve installation the pipe work to which the valve is to be connected should be inspected for cleanliness and freedom from debris. The valve is marked with a directional flow arrow on the body. The valve will function correctly providing it is fitted so that the fluid transported follows the indicated flow direction.

Pegler ProFlow valves are manufactured to exacting standards and, therefore, should not be subjected to misuse.

The following should be avoided:

- careless handling of the valve
- dirt and debris entering the valve through the end ports
- excessive force during assembly and operation

Use suitable hangers close to both ends of the valve in order to remove stresses transmitted by the pipe. Confirm that the pipe threading length is correct to avoid excessive penetration of the pipe into the valve that would otherwise cause damage. Care should be taken to apply jointing compound to the pipe only and not in the valve threads. Surplus compound will then be forced outwards and will not enter the valve. Overuse of compound can lead to valve failure on the body ends.

Threads should be engaged correctly when tightening the valve onto the pipe. The wrench should always be fitted on the body end adjacent to the joint being made. Severe damage can occur to stems, valves and seats by the use of hand wheels or levers larger than those originally supplied by the manufacturer, and by wheel keys.

Press-fit valves include the VSH XPress connectors and these are bronze and are suitable for copper tube, stainless steel and carbon steel tube. The joints are of the leak before press type and utilise the M press profile. Full instructions are on press jointing are available in the VSH XPress technical manual.

mounting

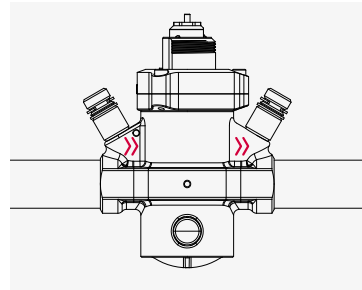

1. an arrow on the Pegler ProFlow 1600 PICV housing indicates the flow direction to be respected.

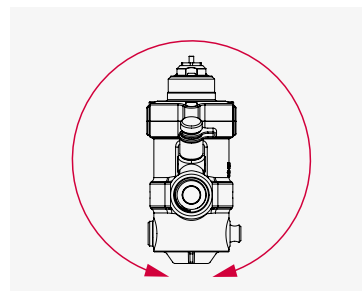

2. the Pegler ProFlow 1600 PICV can be orientated 360° around the pipe axis.

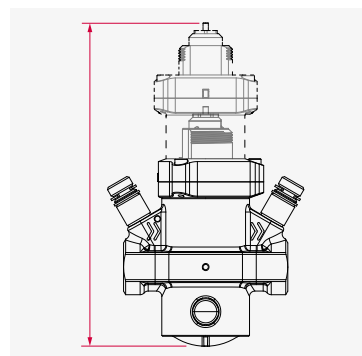

3. additional space is required for the isolate and bypass modes and to allow installation of an actuator following commissioning.

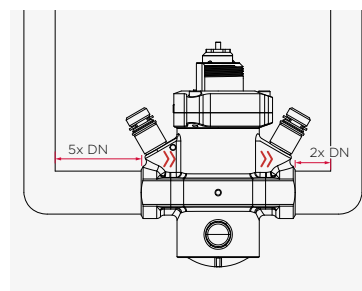

4. 2 x DN straight piping is required before the valve and after any bend and 2 x DN after the valve and before any bend.

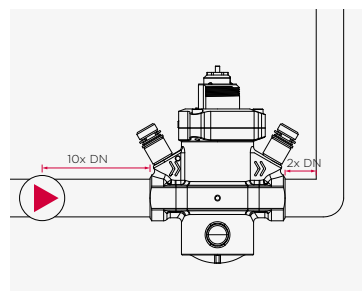

5. 10 x DN straight piping is required when the valve is mounted directly after the system pump and 2 x DN is required after the valve and before any bend.

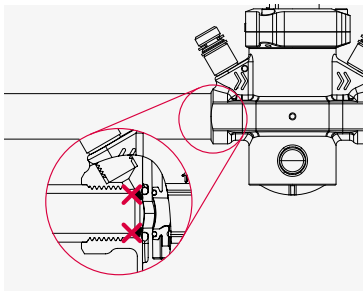

6. loose thread sealant must not hang into the pipe.

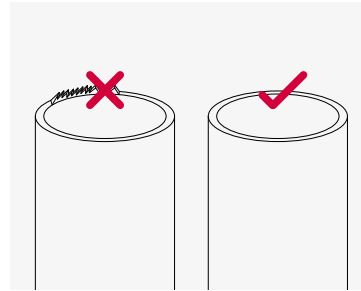

7. deburring of pipe ends is required to prevent system clogging.

8. when installing Pegler ProFlow PS1600 PICV valves please refer to the VSH XPress technical manual for VSH XPress connection instructions.

operation for **system flushing**

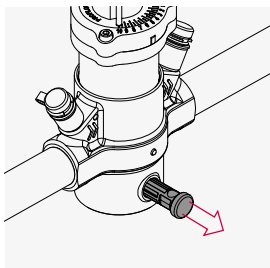

1. the Pegler ProFlow 1600 PICV valve is supplied in bypass position. After installation it should remain in this position until all system flushing operations are completed. Then follow the steps detailed below to enable the dynamic balancing mode, commission and verify the valve.

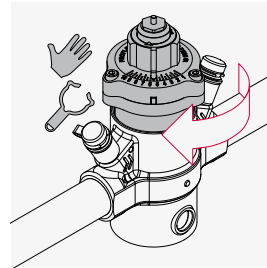

3. continue the clockwise motion until the head goes no further, at this point the Pegler ProFlow 1600 PICV will activate into the operational mode. This can be completed by hand or with the use of an operational tool (see accessories).

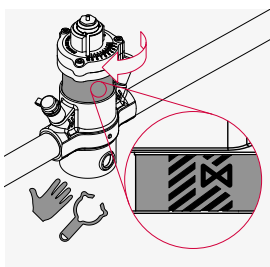

2. to activate the operational mode remove the locking pin. By turning the head clockwise the exposed shuttle markings will demonstrate the isolation mode, the isolation function is active when the isolation symbol is fully visible and the bypass symbol is hidden.

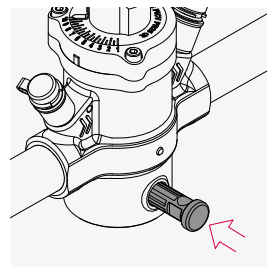

4 **important note.** The locking pin must be re inserted to ensure anti tamper and security.

caution. Suitable hand protection should be worn when operating valves used in extreme temperature applications.

commissioning steps for **regulation**

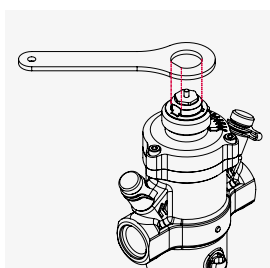

1. Using a setting tool, the spindle can be rotated clockwise and counterclockwise to achieve the desired setting point. (see accessories on page 68 for tool)

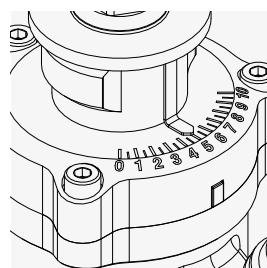

3. the setting indicator allows for accurate positioning from 0 to 10, the clear markings remain in position and preserves the flow setting of the valve even when in isolation or bypass mode, avoiding further costly time on re commissioning and maintenance.

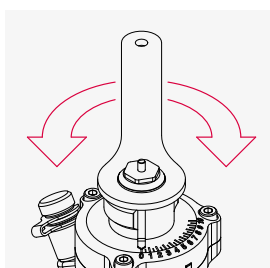

2. the Pegler ProFlow 1600 PICV valve has a visible position indicator displayed on the head of the valve, which is visible both with and without an actuator installed.

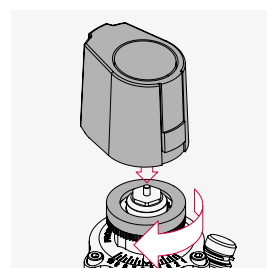

4. screw the adapter ring onto the valve and fit the thermal head onto it. Rotate the lower ring until you hear a click.

There is no need for adapters when the valve and actuator match M30 x 1.5 threads.

Pegler ProFlow 1500 PICV

Unpack the valve and check that the flow paths and valve threads are clean and free from debris. Check the body markings and nameplate, where fitted, to ensure that the correct valve has been selected for installation.

The 1500 PICV DN32, DN40, and DN50 valves are delivered without the mounted indicator to facilitate cartridge removal during flushing. The indicator is provided separately and should be mounted after flushing and before commissioning. Ensure correct mounting with grab ring facing the flat side of the cartridge's head. The flushing plug can help push the positioning ring down.

Before valve installation the pipe work to which the valve is to be connected should be inspected for cleanliness and freedom from debris. The valve is marked with a directional flow arrow on the body. The valve will function correctly providing it is fitted so that the fluid transported follows the indicated flow direction.

Pegler ProFlow valves are manufactured to exacting standards and, therefore, should not be subjected to misuse.

The following should be avoided:

- careless handling of the valve
- dirt and debris entering the valve through the end ports
- excessive force during assembly and operation

Use suitable hangers close to both ends of the valve in order to remove stresses transmitted by the pipe. Confirm that the pipe threading length is correct to avoid excessive penetration of the pipe into the valve that would otherwise cause damage. Care should be taken to apply jointing compound to the pipe only and not in the valve threads. Surplus compound will then be forced outwards and will not enter the valve. Overuse of compound can lead to valve failure on the body ends.

Threads should be engaged correctly when tightening the valve onto the pipe. The wrench should always be fitted on the body end adjacent to the joint being made. Severe damage can occur to stems, valves and seats by the use of hand wheels or levers larger than those originally supplied by the manufacturer, and by wheel keys.

Press-fit valves include the VSH XPress connectors and these are Gunmetal and are suitable for copper tube, stainless steel and carbon steel tube. The joints are of the leak before press type and utilise the M press profile. Full instructions are on press jointing are available in the VSH XPress technical manual.

mounting

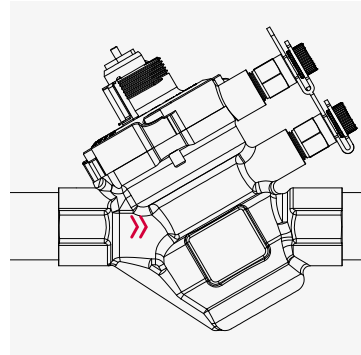

1. an arrow on the Pegler ProFlow 1500 PICV housing indicates the flow direction to be respected

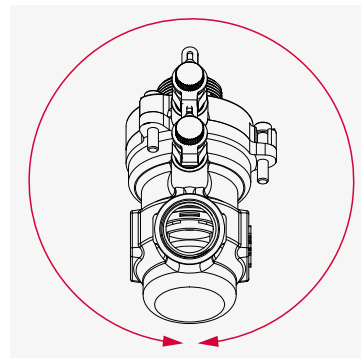

2. the Pegler ProFlow 1500 PICV can be installed in any orientation

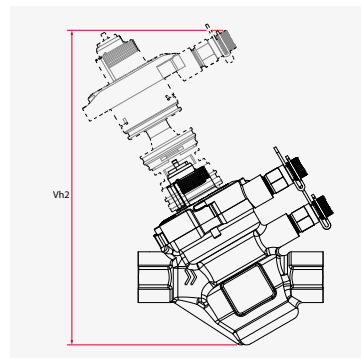

3. additional space is required to remove the cartridge for flushing and for installing an actuator.

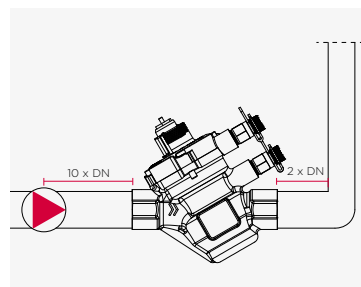

4. 10 x DN straight piping is required when the valve is mounted directly after the system pump

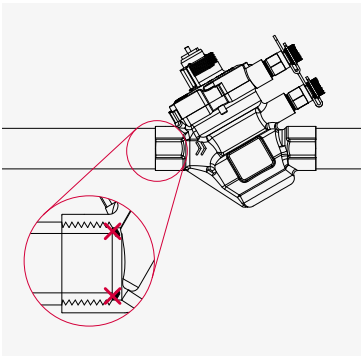

5. 10 x DN straight piping is required when the valve is mounted directly after the system pump and 2 x DN is required after the valve and before any bend

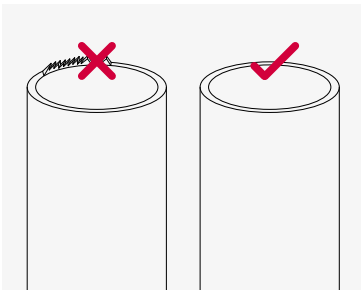

6. deburring of pipe ends is required to prevent system clogging

7. when installing Pegler ProFlow PS1500 PICV valves please refer to the VSH XPress technical manual for VSH XPress connection instructions

Pegler ProFlow 1500 DN15, DN20 and DN25

operation for **system flushing**

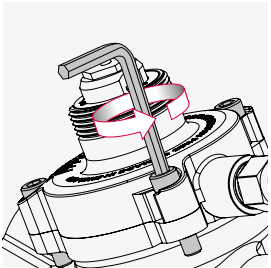

1. loosen (do not remove) cap bolts with Allen Key. Turn anti-clockwise to release.

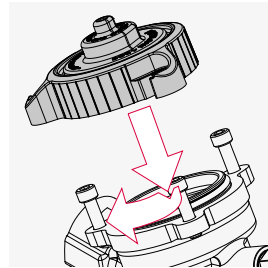

4. fit flushing cap, turn clockwise. engage bolts.

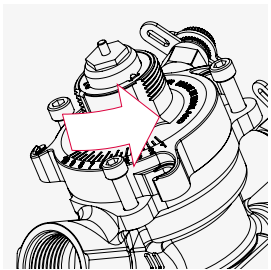

2. rotate the cap head anti-clockwise so free from bolts.

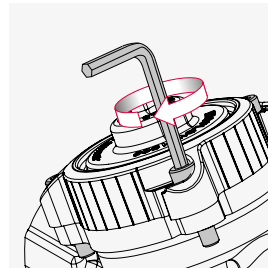

- 5 tighten cap bolts with Allen Key.

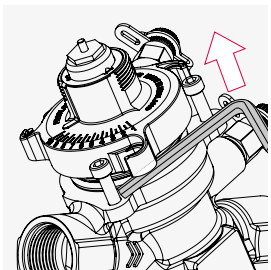

3. use Allen key as leverage to pop cap upwards.

6. Tighten bolts with an Allen key to the below torque:
DN15 and DN20: 1 - 3 Nm, DN25: 4 - 6 Nm.
Valve is ready for flushing.

commissioning steps for **regulation**

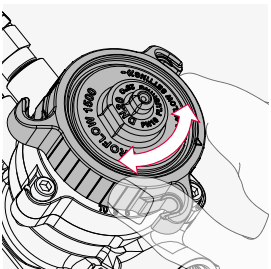

1. turn clockwise to increase flow. Turn anti-clockwise to decrease flow. Use the cap to turn the axis

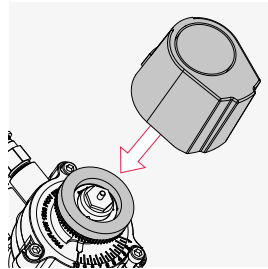

3. install the actuator (using its provided instructions) and any relevant adaptors.

note: the thread on the Pegler ProFlow 1500 PICV is M30 x 1.5.

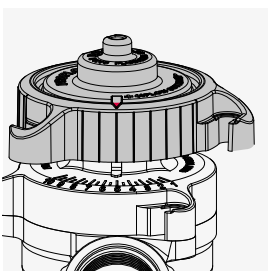

2. set the flow rate using the indicator on the flushing cap.

Pegler ProFlow 1500 DN32, DN40 and DN50

operation for system flushing

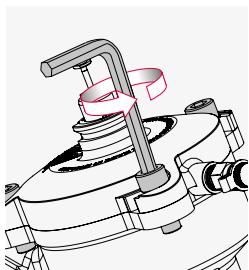

1.* loosen (do not remove) cap bolts with Allen Key. Turn anti-clockwise to release.

* if firm, use spanner between test points to start the rotation

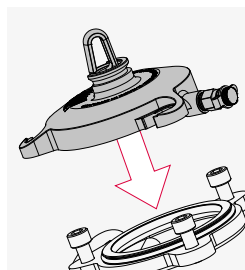

4. fit cap, turn clockwise, engage bolts.

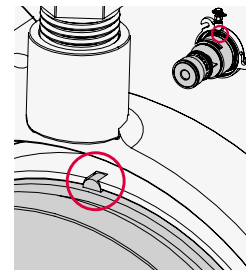

7 refit cartridge into cap. Ensure pip is aligned correctly and cartridge is clean.

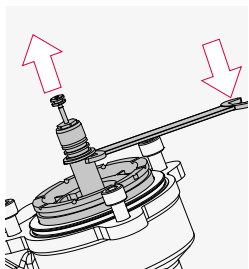

2. carefully lever cartridge up with an appropriate spanner. Keep it clean.

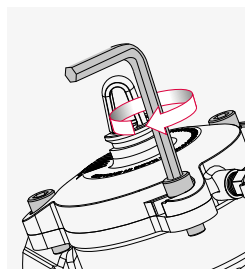

5. tighten bolts with an Allen Key to a torque between 4-6 Nm. Valve is ready for flushing.

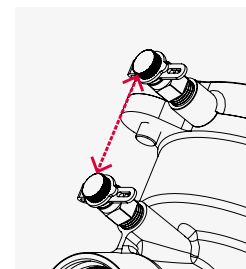

8. refit cap and cartridge into body. Ensure test points are aligned. Tighten to a torque between 4-6 Nm.

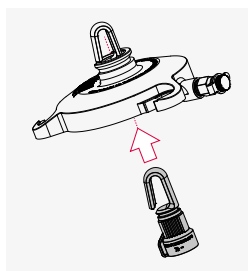

3 insert flushing plug.

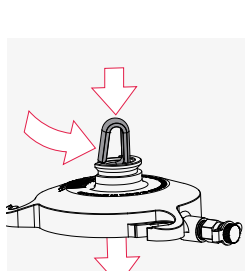

6. remove cap from body after flushing. Remove plug from cap.

commissioning steps for regulation

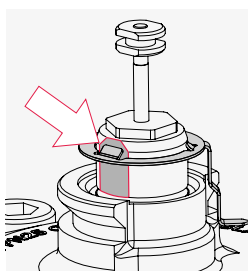

1. align indicator on cartridge.

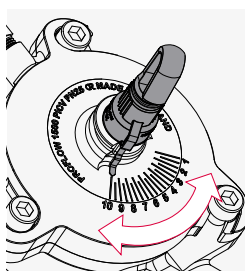

3. turn clockwise to increase flow, turn anti-clockwise to decrease flow. Use the plug to turn the axis.

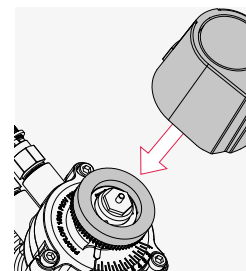

5. install the actuator (using its provided instructions) and any relevant adaptors

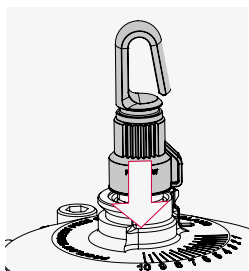

2. use flushing plug to push indicator into place.

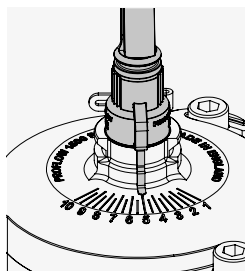

4. set the flow rate using the indicator on the flushing plug.

note: the thread on the Pegler ProFlow 1500 PICV is M30 x 1.5

Pegler ProFlow BC3 balancing computer



handle position: measure



handle position: zero

Verification of flow can be done using a suitable flow measurement device and utilising the built-in test points on the valve. The Pegler ProFlow BC3 balancing computer is supplied with pre-programmed loss coefficient data (Kvs values) allowing a direct measurement of flow rate to be obtained, ensuring the system is balanced correctly to achieve optimum efficiency. To download the app search for Pegler ProFlow BC3 on either Google Play or the App Store.

connecting the Pegler ProFlow BC3 balancing computer

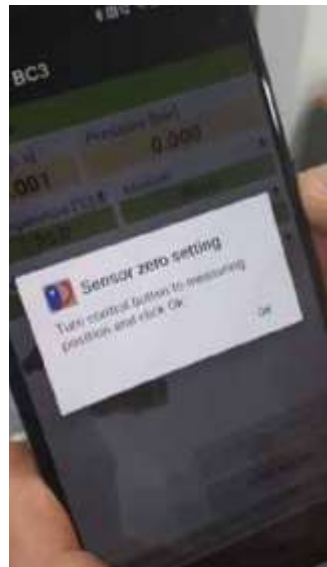

1. connect the hoses to the valve using needle connectors (included).
2. zero the flow meter and bleed air from the hoses. *(See handle positions top right).
3. select the valve (where valve data is not available, a direct Kv can be used for verification, found in the options menu).

All Pegler ProFlow 1600 PICV products have been included as best practice, the differential pressure working range will be the same throughout the selection, and the Pegler ProFlow BC3 will verify this.

results for the Pegler ProFlow 1260 and V955



Flow through the valve is calculated and displayed live on the mobile device screen.

Readings can be saved via the quick records option for ease.

results for the Pegler ProFlow 1600 PICV



live view

The app will display the live pressure loss across the Pegler ProFlow 1600 PICV valve. This can be used to verify the valve is within the working range as shown on the supplied charts, and will be providing a stable flow.

quick reference

The app also provides a quick reference for the Pegler ProFlow 1600 PICV published flow data, the sliding bar confirms the setting point against the required flow rate (please note this is for reference only).

Readings can be saved via the quick records option for ease.

how to use tables and charts

valve sizing and selection

Each balancing valve needs to be sized correctly for optimising the distribution of water in a building's hydronic heating or cooling system, to provide the intended indoor climate at optimum energy efficiency and minimal operating costs. There are multiple options to choose the correct valve size.

valve selection by calculating Kv value

The correct valve size for the Pegler ProFlow 1260 static commissioning valves can be obtained by calculating the Kv value by the following formula:

$$Kv = 36 \frac{Q}{\sqrt{\Delta p}}$$

- Q = flow [l/s]
- Δp = pressure loss [kPa]
- Kv = valve coefficient [m³/h]

Once the Kv value is calculated the corresponding valve size can be found in the table below.

example 1:

| | |
|-------------------------|----------|
| required flow (Q): | 0.15 l/s |
| required pressure drop: | 29 kPa |
| calculated Kv value: | 1.0 |

In the table you will find this Kv value in several places: DN20 standard flow with a presetting of 4.0, DN15 standard flow with a presetting of 4.3 and DN15 medium flow at a presetting of 7.1. It's recommended to use the smallest DN size with medium presetting, in this case DN15 standard flow with presetting 4.3. The tube size can give preference to use the DN20 standard flow valve. The relevant Kv values and presettings are highlighted in the table.

example 2:

| | |
|-------------------------|-----------|
| required flow [Q]: | 0.055 l/s |
| required pressure drop: | 10 kPa |
| calculated Kv value: | 0.63 |

In the table you will find DN20 standard flow with a presetting of 2.0, DN15 standard flow with a presetting of 2.4 and DN15 medium flow at a presetting of 5.2. It's recommended to use the smallest DN size with medium presetting, in this case DN15 medium flow.

presetting table Kvs and Kv values

| Pre-set | DN15 ultra low flow (ULF) | DN15 low flow (LF) | DN15 medium flow (MF) | DN15 standard flow (SF) | DN20 standard flow (SF) | DN25 standard flow (SF) | DN32 standard flow (SF) | DN40 standard flow (SF) | DN50 standard flow (SF) |
|---------------|---------------------------------|--------------------------|-----------------------------|-------------------------------|-------------------------------|-------------------------------|-------------------------------|-------------------------------|-------------------------------|
| | Kvs 0.25 | Kvs 0.49 | Kvs 0.98 | Kvs 2.02 | Kvs 4.43 | Kvs 6.07 | Kvs 11.10 | Kvs 22.26 | Kvs 42.46 |
| | Kv | Kv | Kv | Kv | Kv | Kv | Kv | Kv | Kv |
| 1.2 | 0.04 | 0.08 | 0.15 | 0.43 | 0.49 | 0.91 | 0.73 | 2.43 | 2.92 |
| 1.3 | 0.04 | 0.09 | 0.16 | 0.45 | 0.50 | 0.97 | 1.93 | 2.71 | 3.17 |
| 1.4 | 0.04 | 0.09 | 0.17 | 0.47 | 0.52 | 1.02 | 2.12 | 2.99 | 3.42 |
| 1.5 | 0.05 | 0.10 | 0.18 | 0.48 | 0.54 | 1.08 | 2.32 | 3.27 | 3.67 |
| 1.6 | 0.05 | 0.11 | 0.18 | 0.50 | 0.56 | 1.14 | 2.52 | 3.54 | 3.92 |
| 1.7 | 0.05 | 0.11 | 0.19 | 0.52 | 0.58 | 1.20 | 2.71 | 3.82 | 4.17 |
| 1.8 | 0.05 | 0.12 | 0.20 | 0.53 | 0.59 | 1.26 | 2.91 | 4.10 | 4.42 |
| 1.9 | 0.05 | 0.12 | 0.20 | 0.53 | 0.59 | 1.26 | 2.91 | 4.10 | 4.42 |
| 2.0 | 0.06 | 0.13 | 0.22 | 0.57 | 0.63 | 1.37 | 3.31 | 4.65 | 4.93 |
| 2.1 | 0.06 | 0.14 | 0.23 | 0.58 | 0.65 | 1.43 | 3.51 | 4.93 | 5.18 |
| 2.2 | 0.07 | 0.15 | 0.24 | 0.60 | 0.66 | 1.49 | 3.70 | 5.21 | 5.43 |
| 2.3 | 0.07 | 0.15 | 0.25 | 0.62 | 0.68 | 1.55 | 3.90 | 5.49 | 5.68 |
| 2.4 | 0.07 | 0.16 | 0.26 | 0.63 | 0.70 | 1.60 | 4.10 | 5.77 | 5.93 |
| 2.5 | 0.07 | 0.17 | 0.27 | 0.65 | 0.72 | 1.66 | 4.30 | 6.05 | 6.18 |
| 2.6 | 0.08 | 0.17 | 0.28 | 0.67 | 0.74 | 1.72 | 4.50 | 6.33 | 6.44 |
| 2.7 | 0.08 | 0.18 | 0.28 | 0.68 | 0.75 | 1.78 | 4.70 | 6.61 | 6.69 |
| 2.8 | 0.08 | 0.19 | 0.29 | 0.70 | 0.77 | 1.84 | 4.90 | 6.89 | 6.94 |
| 2.9 | 0.08 | 0.20 | 0.30 | 0.72 | 0.79 | 1.89 | 5.10 | 7.17 | 7.19 |
| 3.0 | 0.09 | 0.20 | 0.31 | 0.74 | 0.81 | 1.95 | 5.30 | 7.45 | 7.44 |
| 3.1 | 0.09 | 0.21 | 0.32 | 0.75 | 0.83 | 2.01 | 5.50 | 7.74 | 7.70 |
| 3.2 | 0.09 | 0.22 | 0.33 | 0.77 | 0.84 | 2.07 | 5.70 | 8.02 | 7.95 |
| 3.3 | 0.10 | 0.22 | 0.34 | 0.79 | 0.86 | 2.13 | 5.90 | 8.31 | 8.20 |
| 3.4 | 0.10 | 0.23 | 0.35 | 0.80 | 0.88 | 2.19 | 6.10 | 8.59 | 8.45 |
| 3.5 | 0.10 | 0.24 | 0.36 | 0.82 | 0.90 | 2.24 | 6.30 | 8.88 | 8.71 |
| 3.6 | 0.10 | 0.24 | 0.37 | 0.84 | 0.92 | 2.30 | 6.51 | 9.16 | 8.96 |
| 3.7 | 0.11 | 0.25 | 0.38 | 0.85 | 0.93 | 2.36 | 6.71 | 9.45 | 9.21 |
| 3.8 | 0.11 | 0.26 | 0.38 | 0.87 | 0.95 | 2.42 | 6.91 | 9.73 | 9.47 |
| 3.9 | 0.11 | 0.26 | 0.39 | 0.89 | 0.97 | 2.48 | 7.11 | 10.01 | 9.72 |
| example 2 4.0 | 0.11 | 0.27 | 0.40 | 0.90 | 0.99 | 2.54 | 7.31 | 10.30 | 9.97 |

| | DN15 ultra low flow (ULF) | DN15 low flow (LF) | DN15 medium flow (MF) | DN15 standard flow (SF) | DN20 standard flow (SF) | DN25 standard flow (SF) | DN32 standard flow (SF) | DN40 standard flow (SF) | DN50 standard flow (SF) |
|----------------------|---------------------------------|--------------------------|-----------------------------|-------------------------------|-------------------------------|-------------------------------|-------------------------------|-------------------------------|-------------------------------|
| | Kvs 0.25 | Kvs 0.49 | Kvs 0.98 | Kvs 2.02 | Kvs 4.43 | Kvs 6.07 | Kvs 11.10 | Kvs 22.26 | Kvs 42.46 |
| Pre-set | Kv | Kv | Kv | Kv | Kv | Kv | Kv | Kv | Kv |
| 4.1 | 0.12 | 0.28 | 0.42 | 0.94 | 1.04 | 2.63 | 7.46 | 10.62 | 10.45 |
| 4.2 | 0.12 | 0.29 | 0.44 | 0.97 | 1.10 | 2.72 | 7.60 | 10.94 | 10.93 |
| <i>example 2</i> 4.3 | 0.13 | 0.29 | 0.46 | 1.00 | 1.15 | 2.81 | 7.75 | 11.27 | 11.41 |
| 4.4 | 0.13 | 0.30 | 0.48 | 1.04 | 1.20 | 2.90 | 7.89 | 11.59 | 11.89 |
| 4.5 | 0.14 | 0.31 | 0.50 | 1.07 | 1.26 | 2.99 | 8.04 | 11.91 | 12.37 |
| 4.6 | 0.14 | 0.32 | 0.52 | 1.10 | 1.31 | 3.09 | 8.18 | 12.23 | 12.85 |
| 4.7 | 0.15 | 0.32 | 0.54 | 1.14 | 1.37 | 3.18 | 8.33 | 12.56 | 13.33 |
| 4.8 | 0.15 | 0.33 | 0.56 | 1.17 | 1.42 | 3.27 | 8.48 | 12.88 | 13.81 |
| 4.9 | 0.16 | 0.34 | 0.57 | 1.20 | 1.47 | 3.36 | 8.62 | 13.20 | 14.29 |
| 5.0 | 0.16 | 0.35 | 0.59 | 1.24 | 1.53 | 3.45 | 8.77 | 13.52 | 14.77 |
| 5.1 | 0.16 | 0.36 | 0.61 | 1.27 | 1.58 | 3.54 | 8.91 | 13.86 | 15.26 |
| <i>example 1</i> 5.2 | 0.17 | 0.36 | 0.63 | 1.31 | 1.64 | 3.64 | 9.06 | 14.19 | 15.74 |
| 5.3 | 0.17 | 0.37 | 0.65 | 1.34 | 1.69 | 3.73 | 9.21 | 14.52 | 16.23 |
| 5.4 | 0.18 | 0.38 | 0.67 | 1.37 | 1.75 | 3.82 | 9.36 | 14.86 | 16.72 |
| 5.5 | 0.18 | 0.39 | 0.69 | 1.41 | 1.80 | 3.91 | 9.51 | 15.19 | 17.21 |
| 5.6 | 0.19 | 0.40 | 0.71 | 1.44 | 1.86 | 4.01 | 9.65 | 15.52 | 17.69 |
| 5.7 | 0.19 | 0.40 | 0.73 | 1.47 | 1.91 | 4.10 | 9.80 | 15.86 | 18.18 |
| 5.8 | 0.20 | 0.41 | 0.75 | 1.51 | 1.96 | 4.19 | 9.95 | 16.19 | 18.67 |
| 5.9 | 0.20 | 0.42 | 0.77 | 1.54 | 2.02 | 4.29 | 10.10 | 16.52 | 19.16 |
| 6.0 | 0.20 | 0.43 | 0.78 | 1.58 | 2.07 | 4.38 | 10.24 | 16.85 | 19.64 |
| 6.1 | 0.21 | 0.44 | 0.81 | 1.61 | 2.13 | 4.47 | 10.40 | 17.20 | 20.14 |
| 6.2 | 0.21 | 0.44 | 0.82 | 1.64 | 2.18 | 4.57 | 10.55 | 17.55 | 20.64 |
| 6.3 | 0.22 | 0.45 | 0.84 | 1.68 | 2.24 | 4.66 | 10.70 | 17.90 | 21.14 |
| 6.4 | 0.22 | 0.46 | 0.86 | 1.71 | 2.29 | 4.76 | 10.85 | 18.24 | 21.64 |
| 6.5 | 0.23 | 0.47 | 0.88 | 1.75 | 2.35 | 4.85 | 11.00 | 18.59 | 22.14 |
| 6.6 | 0.23 | 0.48 | 0.90 | 1.78 | 2.41 | 4.95 | 11.15 | 18.94 | 22.63 |
| 6.7 | 0.24 | 0.48 | 0.92 | 1.81 | 2.46 | 5.04 | 11.30 | 19.28 | 23.13 |
| 6.8 | 0.24 | 0.49 | 0.94 | 1.85 | 2.52 | 5.13 | 11.45 | 19.63 | 23.63 |
| 6.9 | 0.25 | 0.50 | 0.96 | 1.88 | 2.57 | 5.23 | 11.60 | 19.98 | 24.13 |
| 7.0 | 0.25 | 0.51 | 0.98 | 1.92 | 2.63 | 5.32 | 11.75 | 20.32 | 24.63 |
| 7.1 | 0.25 | 0.52 | 1.00 | 1.95 | 2.68 | 5.42 | 11.90 | 20.69 | 25.14 |
| 7.2 | 0.26 | 0.52 | 1.02 | 1.99 | 2.74 | 5.52 | 12.06 | 21.05 | 25.65 |
| 7.3 | 0.26 | 0.53 | 1.04 | 2.02 | 2.79 | 5.61 | 12.21 | 21.41 | 26.16 |
| 7.4 | 0.27 | 0.54 | 1.06 | 2.06 | 2.85 | 5.71 | 12.37 | 21.77 | 26.67 |
| 7.5 | 0.27 | 0.55 | 1.08 | 2.09 | 2.90 | 5.81 | 12.52 | 22.13 | 27.18 |
| 7.6 | 0.27 | 0.55 | 1.08 | 2.09 | 2.96 | 5.90 | 12.67 | 22.49 | 27.68 |
| 7.7 | 0.27 | 0.55 | 1.08 | 2.09 | 3.02 | 6.00 | 12.83 | 22.49 | 28.19 |
| 7.8 | 0.27 | 0.55 | 1.08 | 2.09 | 3.07 | 6.10 | 12.98 | 22.49 | 28.19 |
| 7.9 | 0.27 | 0.55 | 1.08 | 2.09 | 3.07 | 6.19 | 13.13 | 22.49 | 28.19 |

checking flow rate using the flow signal chart

It is recommended, when using the orifice plate in the Pegler ProFlow 1260 valves to measure flow rate or to set the valve, to use a manometer or electronic flow computer that can instantly convert the Kvs value into a live flow rate. If the device being used does not have this functionality, the charts below can be used to determine the flow rate or signal.

for checking the flow rate follow the steps below:

- record the signal measured from the orifice plate in kPa (convert if necessary). In the example below the signal is 5kPa.
- identify the class of valve. In the example below this is a DN15 medium flow (DN15 MF) valve.
- draw a horizontal line from the measured signal to the line for the class of valve being measured.
- draw a vertical line down to the x-axis from where the horizontal line meets the valve line.
- read the flow rate from where the vertical line crosses the x-axis. This is 220 l/h, the current flow rate in the valve.

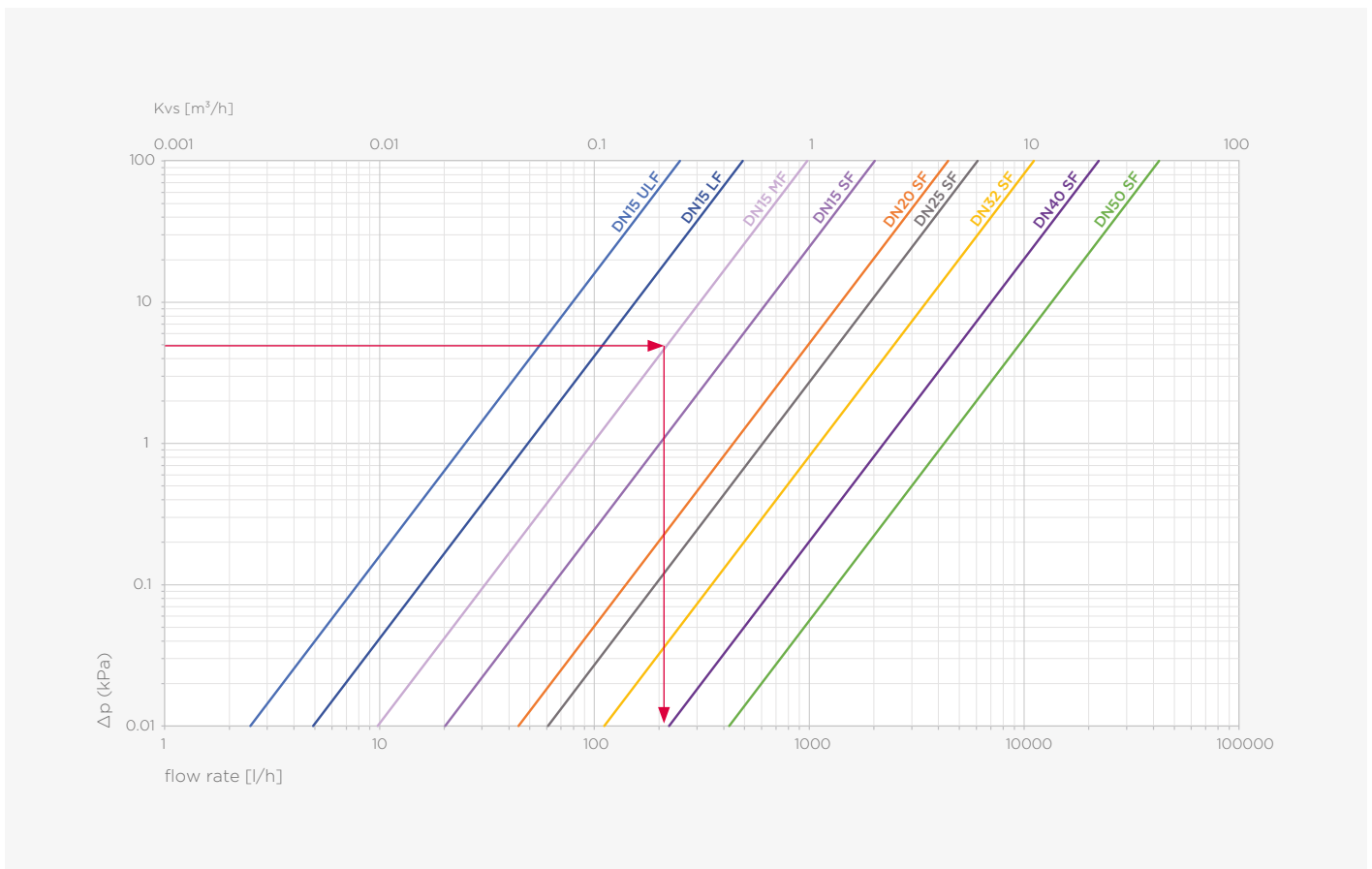

Pegler ProFlow 1260 flow data signal

identifying the target signal using a known flow rate.

If the target flow rate is known and the valve needs commissioning then the target orifice plate signal can be determined.

this can be done by using the method below:

- draw a vertical line up from the target flow rate on the x-axis until it meets the line for the valve to be set. The example below shows a 100 l/h flow rate requirement for a DN15 low flow (DN15 LF) valve.
- draw a horizontal line from where the vertical line meets the valve line to the y-axis.
- read the value where this line meets the y-axis. In the example below this is 4.2 kPa, the signal value the valve needs to be set to.

Connect a manometer to the valve and adjust the handle until the signal matches the value identified from the chart, then set this valve to the desired flow rate.

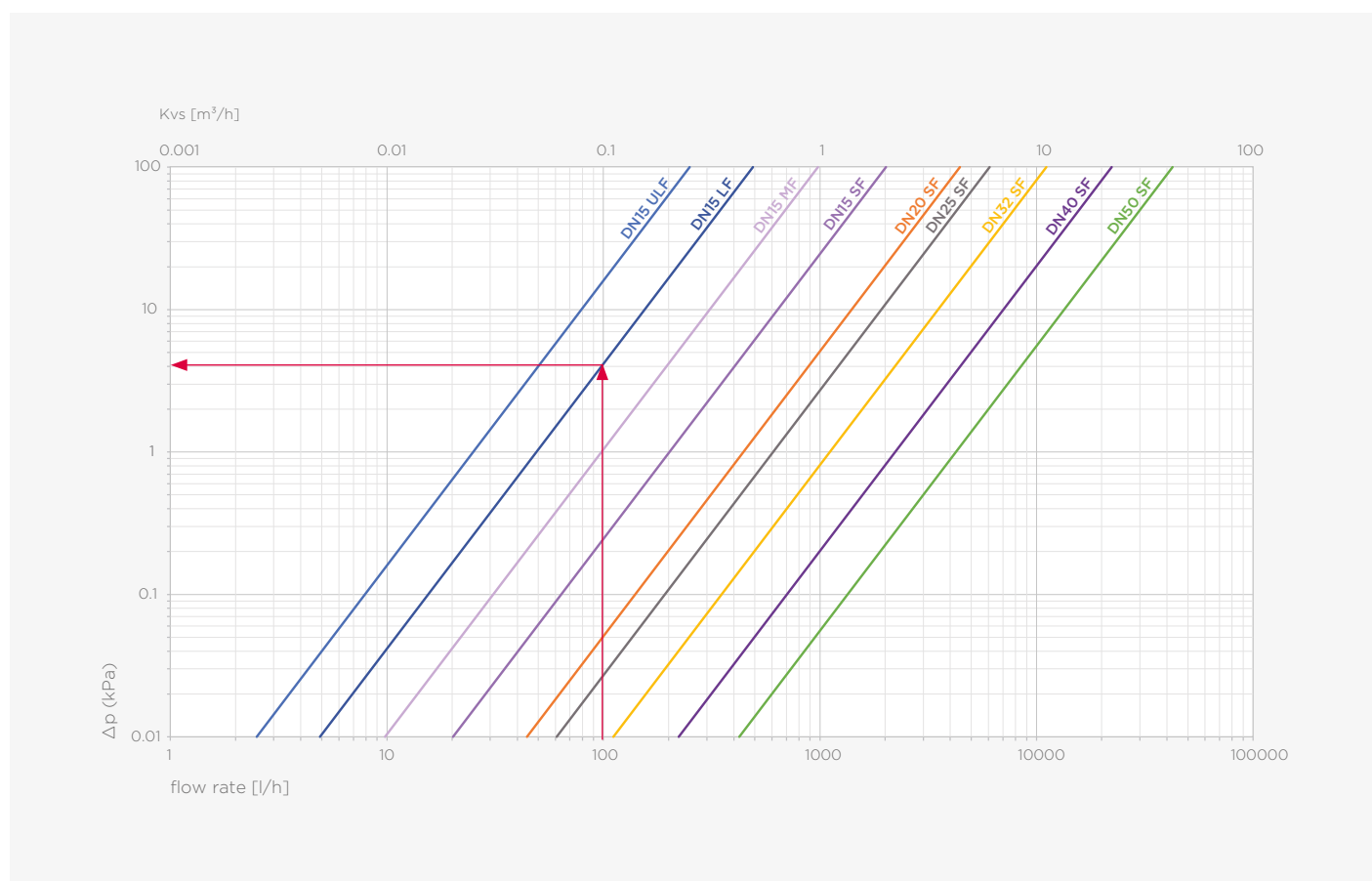

Pegler ProFlow 1260 flow data signal

valve size selection by a design flow rate chart

The correct valve size can be obtained for the Pegler ProFlow 1260 static commissioning valves by using the flow rate chart below:

example:

required flow: 0.07 l/s = 252 l/h
 allowable pressure drop: 10 kPa

for selecting a valve by a design flow rate chart follow the steps below:

- draw a vertical line up from the desired flow rate.
- where the line meets the solid coloured bar, this indicates the suitable valve which has a maximum pressure loss and signal less than 5 kPa.
- where the line crosses a hatched bar this indicates the valve is suitable if an increased pressure loss and signal of up to 10 kPa is acceptable.
- it is recommended to select a valve using the solid coloured bar where possible, as it will provide more accuracy and noise reduction. In some cases however, the hatched bar area may offer a chance to downsize the valve, which may save installation costs.

In the example below the red line is drawn up from the desired flow rate (0.07 l/s) and crosses the solid bar of the DN15 standard flow and the hatched bar of the DN15 medium flow. In this example a pressure loss of 10 kPa is allowed so either valve could be selected. As both valves are DN15 it is recommended to select the DN15 standard flow as it crosses the solid section of the bar.

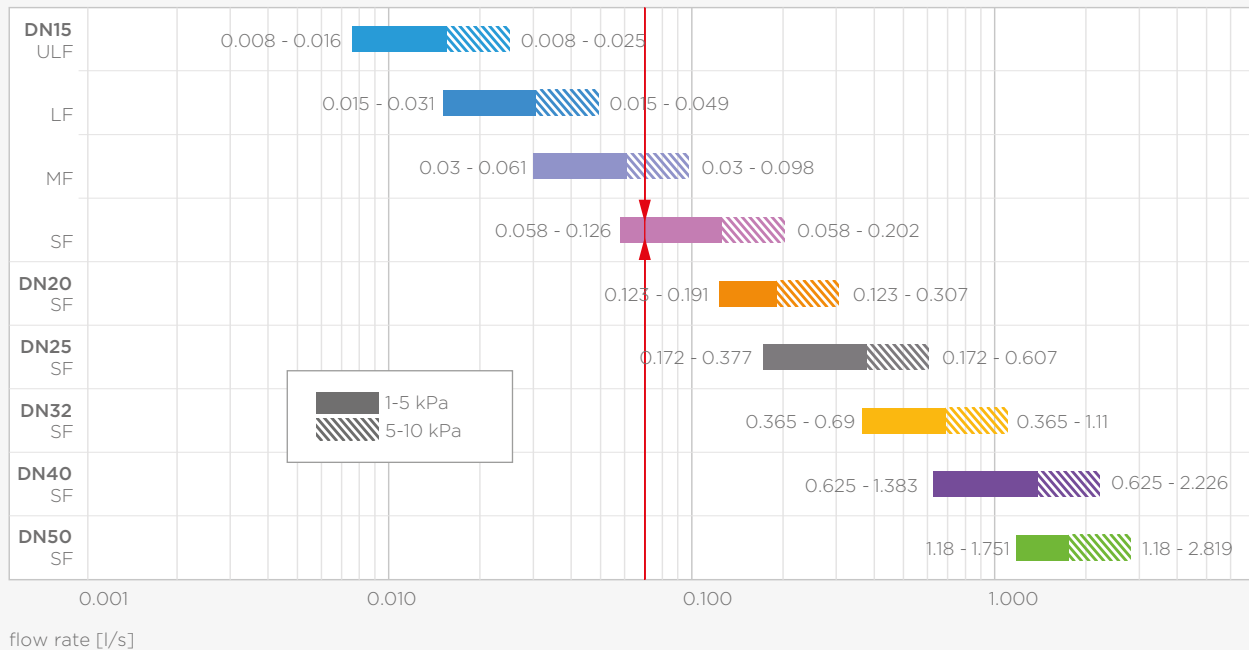

Pegler ProFlow 1260 design flow rate chart

using pre-setting data

The charts are provided for pre-setting verification and can be found in the Pegler ProFlow balancing charts booklet. Here is an example how to utilize the published charts and how to verify the flow rate when using a balancing computer.

example

| | |
|-------------------------|----------------------------------|
| required flow: | 0.15 l/s (vertical line) |
| required pressure drop: | 29 kPa (horizontal line) |
| setting: | 4.0 (intersection of both lines) |

In case of overlap it's recommended to use the smallest DN size.

All presetting charts can be found in the Pegler ProFlow balancing charts booklet.

flow measuring

Verification of flow can be measured using a suitable flow measurement device on the valves test points. The Pegler ProFlow BC3 balancing computer is pre-programmed with loss coefficient data (Kvs values) for both the Pegler ProFlow 1260 and V955 allowing direct measurement of flow rate to be obtained, ensuring the system is balanced correctly for optimum efficiency. Using the Pegler ProFlow BC3 balancing computer is further described on page 28.

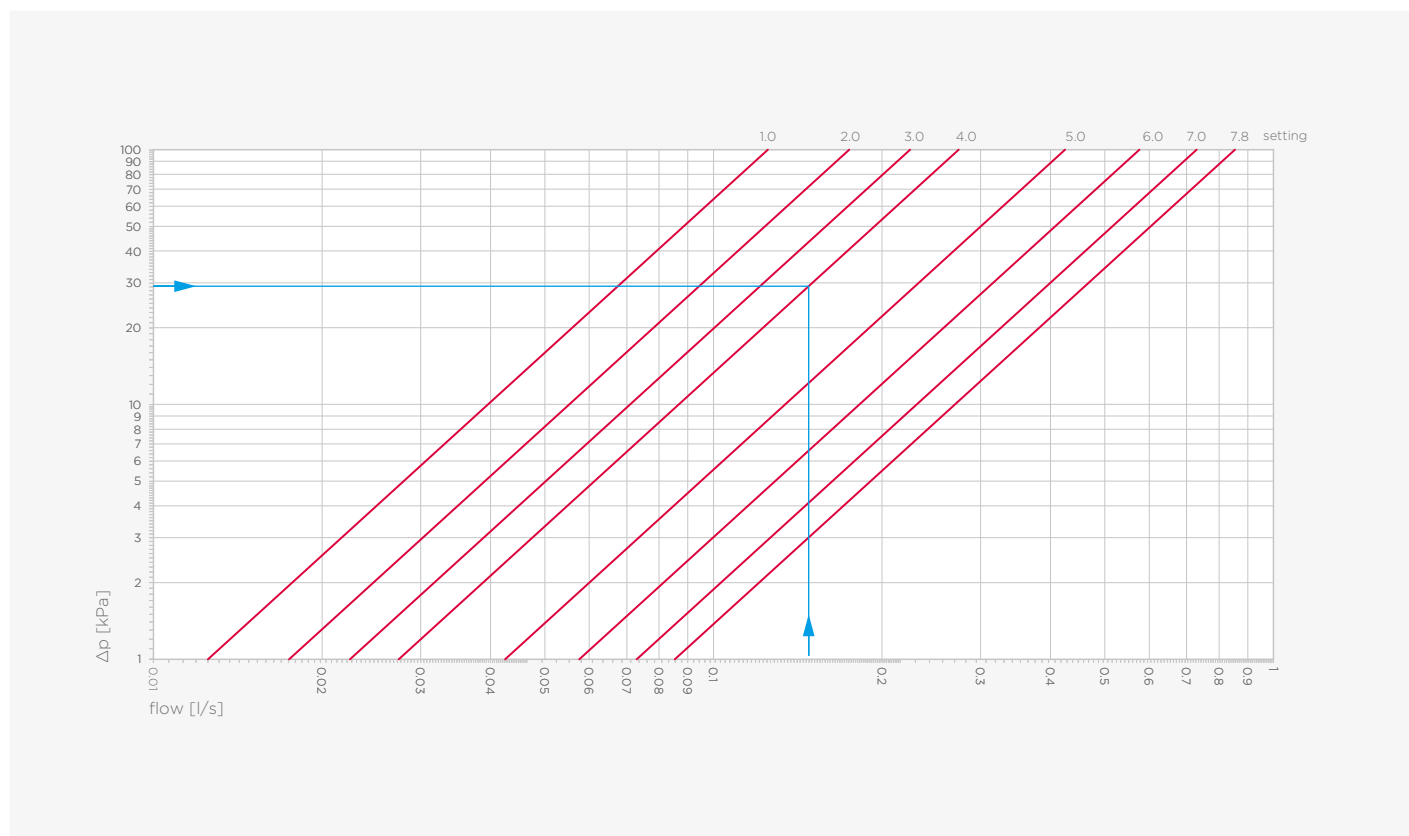

Pegler ProFlow 1260 DN20 standard flow - hand wheel setting

warranty

Please contact Aalberts integrated piping systems for the most recent warranty conditions that apply to Pegler ProFlow.





Pegler ProFlow
balancing
valves

1260 Pegler ProFlow static balancing valve (2 x female thread)

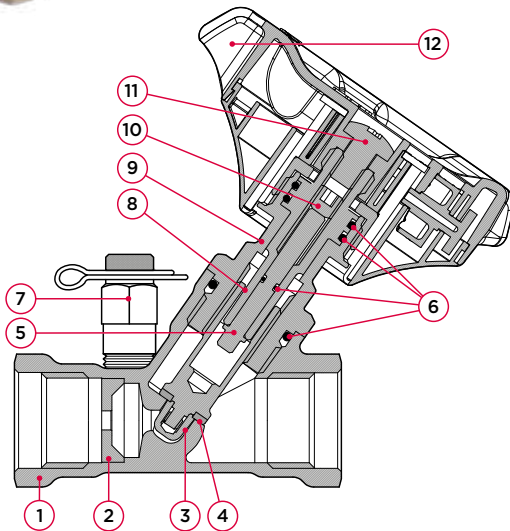

specifications

- max. operating pressure 20 bar
- operating temperature -10°C to 120°C
- fixed orifice measuring (FODRV)
- handle position indicator
- meets BS7350
- includes memory stop
- includes test points

| no. | component | material |
|-----|------------------|----------------------------|
| 1 | body | brass (CW511L) |
| 2 | orifice plate | brass (CW511L) |
| 3 | disc | brass (CW511L) |
| 4 | disc seal | PTFE |
| 5 | regulator pin | brass (CW511L) |
| 6 | o-rings | EPDM |
| 7 | test points | DZR brass (CW602N) |
| 8 | spindle | brass (CW511L) |
| 9 | bonnet | brass (CW511L) |
| 10 | adjustment screw | brass (CW511L) |
| 11 | set screw | stainless steel (AISI 304) |
| 12 | handle | 30% glass filled PA 66 |

maximum pressure conditions [bar]

| max. pressure | test pressure shell | test pressure seat |
|---------------|---------------------|--------------------|
| 20 | 30 | 22 |

pressure equipment directive category

| | |
|----------------|-----|
| all dimensions | SEP |
|----------------|-----|

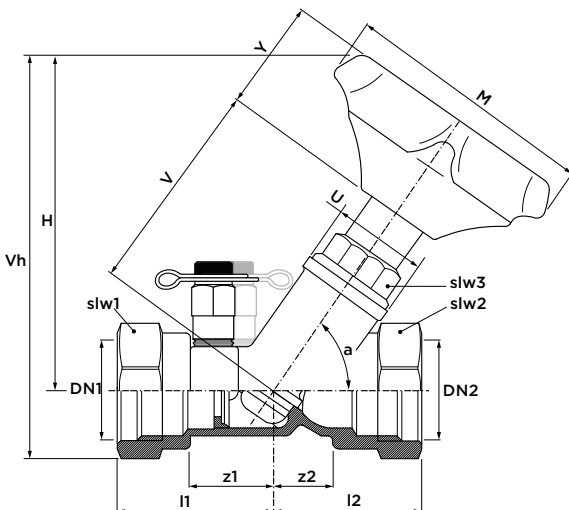

| dimension | article no. | weight [kg] | l1 | l2 | z1 | z2 | U [Ø] | V | Y | M | H | Vh | a [°] | slw1/slw2 | slw3 |
|----------------|-------------|-------------|----|----|----|----|-------|----|----|----|-----|-----|-------|-----------|------|
| G½" (DN15) ULF | 126039 | 0.44 | 36 | 38 | 19 | 21 | 27 | 32 | 38 | 90 | 92 | 107 | 55 | 28 | 25 |
| G½" (DN15) LF | 126022 | 0.44 | 36 | 38 | 19 | 21 | 27 | 32 | 38 | 90 | 92 | 107 | 55 | 28 | 25 |
| G½" (DN15) MF | 126043 | 0.44 | 36 | 38 | 19 | 21 | 27 | 32 | 38 | 90 | 92 | 107 | 55 | 28 | 25 |
| G½" (DN15) SF | 126023 | 0.44 | 36 | 38 | 19 | 21 | 27 | 32 | 38 | 90 | 92 | 107 | 55 | 28 | 25 |
| G¾" (DN20) SF | 126024 | 0.58 | 34 | 43 | 18 | 24 | 27 | 38 | 38 | 90 | 96 | 114 | 55 | 32 | 25 |
| G1" (DN25) SF | 126025 | 0.84 | 44 | 51 | 24 | 31 | 33 | 45 | 38 | 90 | 108 | 131 | 55 | 41 | 25 |
| G1¼" (DN32) SF | 126026 | 1.22 | 50 | 66 | 29 | 45 | 41 | 56 | 38 | 90 | 126 | 154 | 55 | 50 | 32 |
| G1½" (DN40) SF | 126027 | 1.51 | 52 | 67 | 31 | 46 | 60 | 62 | 38 | 90 | 132 | 163 | 55 | 55 | 35 |
| G2" (DN50) SF | 126028 | 2.55 | 69 | 87 | 38 | 58 | 58 | 74 | 38 | 90 | 151 | 189 | 55 | 70 | 35 |

| dimension | Kv [m ² /h] | Kvs [m ² /h] | flow [l/s] | | flow [l/min] | | flow [l/h] | |
|----------------|------------------------|-------------------------|------------|-------|--------------|--------|------------|--------|
| | | | min. | max. | min. | max. | min. | max. |
| G½" (DN15) ULF | 0.27 | 0.25 | 0.008 | 0.016 | 0.46 | 0.94 | 27.4 | 56.2 |
| G½" (DN15) LF | 0.55 | 0.49 | 0.015 | 0.031 | 0.91 | 1.84 | 54.7 | 110.5 |
| G½" (DN15) MF | 1.08 | 0.98 | 0.030 | 0.061 | 1.80 | 3.67 | 108.0 | 220.0 |
| G½" (DN15) SF | 2.09 | 2.02 | 0.058 | 0.126 | 3.49 | 7.54 | 209.2 | 452.5 |
| G¾" (DN20) SF | 3.07 | 4.43 | 0.123 | 0.191 | 7.37 | 11.45 | 442.4 | 686.9 |
| G1" (DN25) SF | 6.19 | 6.07 | 0.172 | 0.377 | 10.32 | 22.61 | 619.2 | 1356.8 |
| G1¼" (DN32) SF | 13.13 | 11.10 | 0.365 | 0.690 | 21.89 | 41.38 | 1313.3 | 2482.6 |
| G1½" (DN40) SF | 22.49 | 22.26 | 0.625 | 1.383 | 37.48 | 82.95 | 2248.9 | 4977.0 |
| G2" (DN50) SF | 28.19 | 42.46 | 1.180 | 1.751 | 70.77 | 105.07 | 4246.2 | 6304.3 |

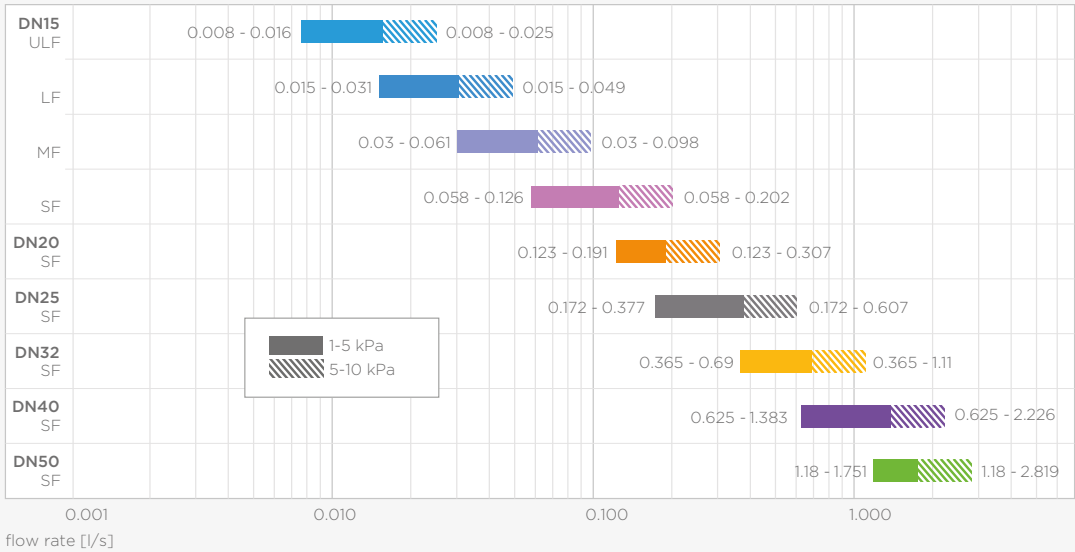

flow rate

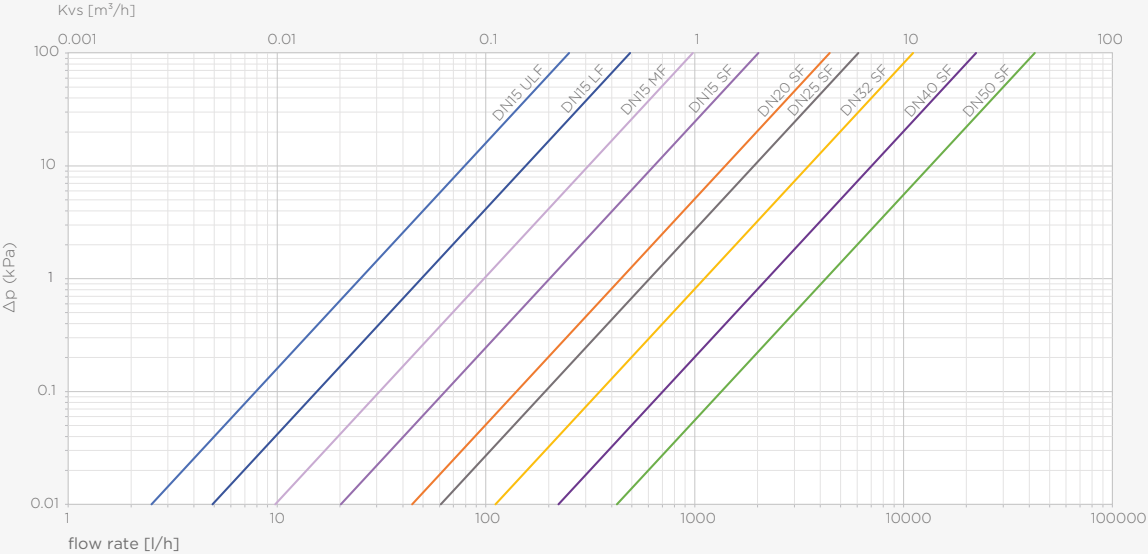

pressure loss

1260PD Pegler ProFlow static balancing valve with drain
(2 x female thread)

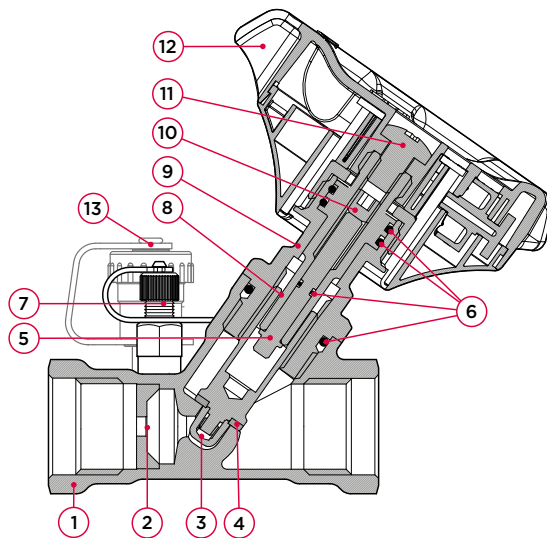

specifications

- max. operating pressure 20 bar
- operating temperature -10°C to 120°C
- fixed orifice measuring (FODRV)
- handle position indicator
- meets BS7350
- includes memory stop
- includes test points

| no. | component | material |
|-----|------------------|----------------------------|
| 1 | body | brass (CW511L) |
| 2 | orifice plate | brass (CW511L) |
| 3 | disc | brass (CW511L) |
| 4 | disc seal | PTFE |
| 5 | regulator pin | brass (CW511L) |
| 6 | o-rings | EPDM |
| 7 | test points | DZR brass (CW602N) |
| 8 | spindle | brass (CW511L) |
| 9 | bonnet | brass (CW511L) |
| 10 | adjustment screw | brass (CW511L) |
| 11 | set screw | stainless steel (AISI 304) |
| 12 | handle | 30% glass filled PA 66 |
| 13 | drain | brass (CW511L) |

maximum pressure conditions [bar]

| max. pressure | test pressure shell | test pressure seat |
|---------------|---------------------|--------------------|
| 20 | 30 | 22 |

pressure equipment directive category

| | |
|----------------|-----|
| all dimensions | SEP |
|----------------|-----|

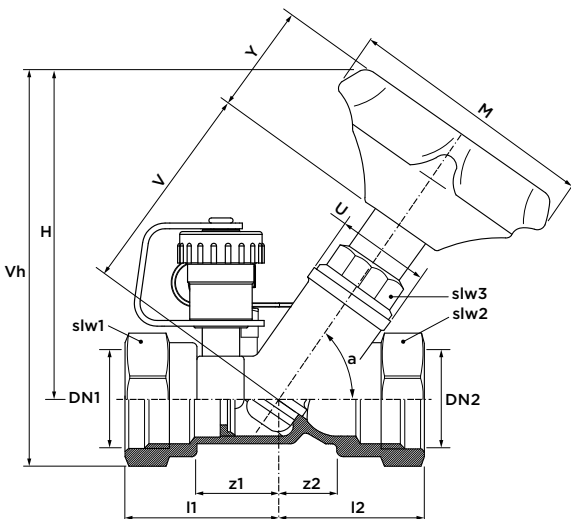

| dimension | article no. | weight (kg) | l1 | l2 | z1 | z2 | U [Ø] | V | Y | M | H | Vh | a [°] | slw1/sl2 | slw3 |
|----------------|-------------|-------------|----|----|----|----|-------|----|----|----|-----|-----|-------|----------|------|
| G½" (DN15) ULF | 123460391 | 0,46 | 36 | 38 | 19 | 21 | 27 | 32 | 38 | 90 | 92 | 107 | 55 | 28 | 25 |
| G½" (DN15) LF | 123460392 | 0,46 | 36 | 38 | 19 | 21 | 27 | 32 | 38 | 90 | 92 | 107 | 55 | 28 | 25 |
| G½" (DN15) MF | 123460393 | 0,46 | 36 | 38 | 19 | 21 | 27 | 32 | 38 | 90 | 92 | 107 | 55 | 28 | 25 |
| G½" (DN15) SF | 123460394 | 0,46 | 36 | 38 | 19 | 21 | 27 | 32 | 38 | 90 | 92 | 107 | 55 | 28 | 25 |
| G¾" (DN20) SF | 123460395 | 0,53 | 34 | 43 | 18 | 24 | 27 | 38 | 38 | 90 | 96 | 114 | 55 | 32 | 25 |
| G1" (DN25) SF | 123460396 | 0,97 | 44 | 51 | 24 | 31 | 33 | 45 | 38 | 90 | 108 | 131 | 55 | 41 | 25 |
| G1¼" (DN32) SF | 123460397 | 1,3 | 50 | 66 | 29 | 45 | 41 | 56 | 38 | 90 | 126 | 154 | 55 | 50 | 32 |
| G1½" (DN40) SF | 123460398 | 1,58 | 52 | 67 | 31 | 46 | 60 | 62 | 38 | 90 | 132 | 163 | 55 | 55 | 35 |
| G2" (DN50) SF | 123460399 | 2,52 | 69 | 87 | 38 | 58 | 58 | 74 | 38 | 90 | 151 | 189 | 55 | 70 | 35 |

| dimension | Kv [m ² /h] | Kvs [m ² /h] | flow [l/s] | | flow [l/min] | | flow [l/h] | |
|-----------------|------------------------|-------------------------|------------|-------|--------------|--------|------------|--------|
| | | | min. | max. | min. | max. | min. | max. |
| G½" (DN15) ULF | 0.27 | 0.25 | 0.008 | 0.016 | 0.46 | 0.94 | 27.4 | 56.2 |
| G½" (DN15) LF | 0.55 | 0.49 | 0.015 | 0.031 | 0.91 | 1.84 | 54.7 | 110.5 |
| G½" (DN15) MF | 1.08 | 0.98 | 0.030 | 0.061 | 1.80 | 3.67 | 108.0 | 220.0 |
| G½" (DN15) SF | 2.09 | 2.02 | 0.058 | 0.126 | 3.49 | 7.54 | 209.2 | 452.5 |
| G¾" (DN20) SF | 3.07 | 4.43 | 0.123 | 0.191 | 7.37 | 11.45 | 442.4 | 686.9 |
| G1" (DN25) SF | 6.19 | 6.07 | 0.172 | 0.377 | 10.32 | 22.61 | 619.2 | 1356.8 |
| G1 ¼" (DN32) SF | 13.13 | 11.10 | 0.365 | 0.690 | 21.89 | 41.38 | 1313.3 | 2482.6 |
| G1 ½" (DN40) SF | 22.49 | 22.26 | 0.625 | 1.383 | 37.48 | 82.95 | 2248.9 | 4977.0 |
| G2" (DN50) SF | 28.19 | 42.46 | 1.180 | 1.751 | 70.77 | 105.07 | 4246.2 | 6304.3 |

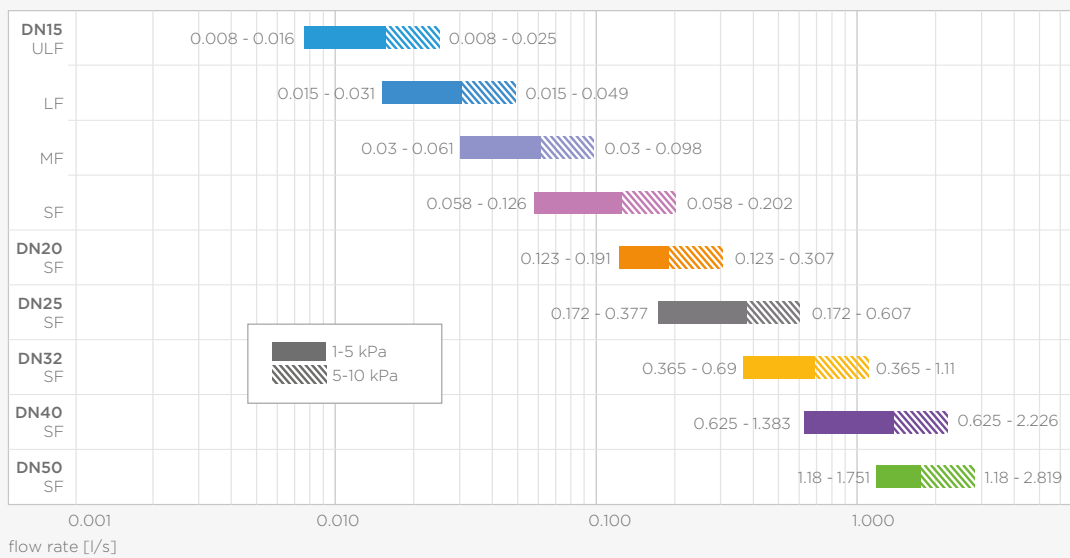

flow rate

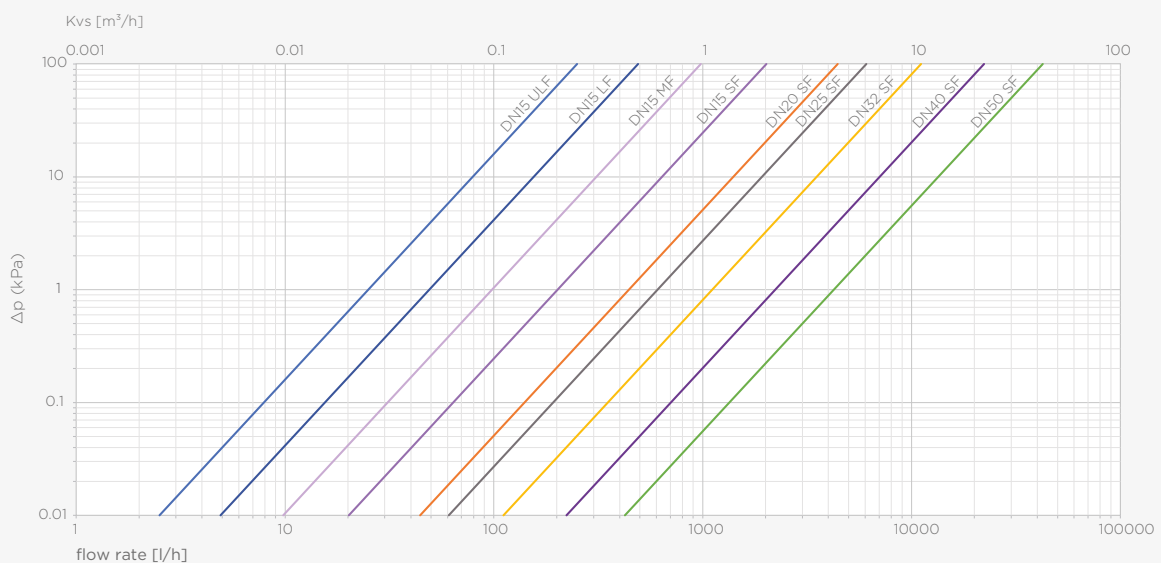

pressure loss

PS1260 Pegler ProFlow static balancing valve
(2x press)

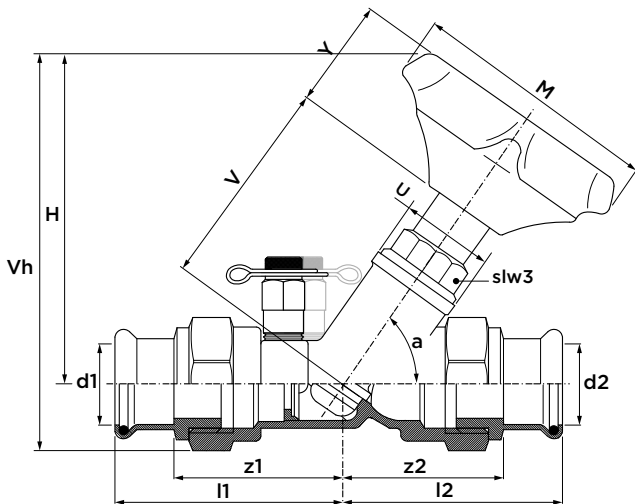
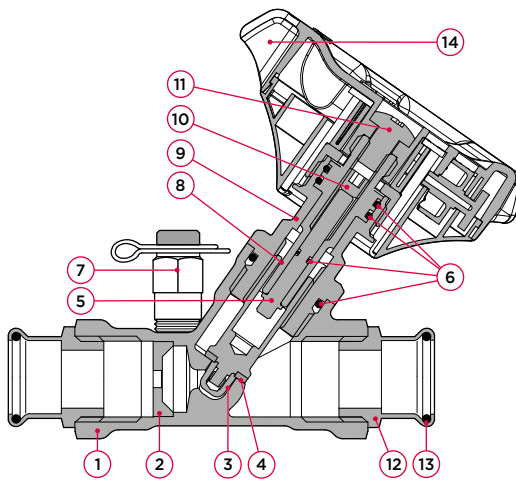

specifications

- max. operating pressure 16 bar
- operating temperature -10°C to 110°C
- VSH XPress gunmetal ends for carbon steel, stainless steel and copper tube
- fixed orifice measuring (FODRV)
- handle with visual digital positioning indicator
- memory stop for setting fixation
- test points for needle connection

| no. | component | material |
|-----|------------------|----------------------------|
| 1 | body | brass (CW511L) |
| 2 | orifice plate | brass (CW511L) |
| 3 | disc | brass (CW511L) |
| 4 | disc seal | PTFE |
| 5 | regulator pin | brass (CW511L) |
| 6 | o-rings | EPDM |
| 7 | test points | DZR brass (CW602N) |
| 8 | spindle | brass (CW511L) |
| 9 | bonnet | brass (CW511L) |
| 10 | adjustment screw | brass (CW511L) |
| 11 | set screw | stainless steel (AISI 304) |
| 12 | end connection | gunmetal (CC499K) |
| 13 | o-ring | EPDM |
| 14 | handle | 30% glass filled PA 66 |

maximum pressure [bar]

| operating pressure | test pressure shell | test pressure seat |
|--------------------|---------------------|--------------------|
| 16 | 24 | 17.6 |

pressure equipment directive category

| | |
|----------------|-----|
| all dimensions | SEP |
|----------------|-----|

| dimension | article no. | weight [kg] | l1 | l2 | z1 | z2 | U [Ø] | V | Y | M | H | Vh | a [°] | slw3 |
|---------------|-------------|-------------|-----|-----|----|----|-------|----|----|----|-----|-----|-------|------|
| 15 (DN15) ULF | 126087 | 0.55 | 57 | 59 | 37 | 39 | 27 | 32 | 38 | 90 | 92 | 107 | 55 | 25 |
| 15 (DN15) LF | 126029 | 0.55 | 57 | 59 | 37 | 39 | 27 | 32 | 38 | 90 | 92 | 107 | 55 | 25 |
| 15 (DN15) MF | 126088 | 0.55 | 57 | 59 | 37 | 39 | 27 | 32 | 38 | 90 | 92 | 107 | 55 | 25 |
| 15 (DN15) SF | 126030 | 0.55 | 57 | 59 | 37 | 39 | 27 | 32 | 38 | 90 | 92 | 107 | 55 | 25 |
| 18 (DN15) LF | 126134 | 0.55 | 58 | 60 | 38 | 40 | 27 | 32 | 38 | 90 | 92 | 107 | 55 | 25 |
| 18 (DN15) SF | 126135 | 0.55 | 58 | 60 | 38 | 40 | 33 | 32 | 38 | 90 | 92 | 107 | 55 | 25 |
| 22 (DN20) SF | 126031 | 0.67 | 57 | 66 | 36 | 45 | 27 | 38 | 38 | 90 | 96 | 114 | 55 | 25 |
| 28 (DN25) SF | 126032 | 0.99 | 70 | 78 | 47 | 55 | 33 | 45 | 38 | 90 | 108 | 131 | 55 | 25 |
| 35 (DN32) SF | 126033 | 1.58 | 79 | 95 | 53 | 69 | 41 | 56 | 38 | 90 | 126 | 154 | 55 | 32 |
| 42 (DN40) SF | 126034 | 2.05 | 88 | 103 | 58 | 73 | 60 | 62 | 38 | 90 | 132 | 163 | 55 | 35 |
| 54 (DN50) SF | 126035 | 3.36 | 112 | 130 | 77 | 95 | 58 | 74 | 38 | 90 | 151 | 189 | 55 | 35 |

| dimension | Kv [m³/h] | Kvs [m³/h] | flow [l/s] | | flow [l/min] | | flow [l/h] | |
|---------------|-----------|------------|------------|-------|--------------|--------|------------|--------|
| | | | min. | max. | min. | max. | min. | max. |
| 15 (DN15) ULF | 0.27 | 0.25 | 0.008 | 0.016 | 0.46 | 0.94 | 27.4 | 56.2 |
| 15 (DN15) LF | 0.55 | 0.49 | 0.015 | 0.031 | 0.91 | 1.84 | 54.7 | 110.5 |
| 15 (DN15) MF | 1.08 | 0.98 | 0.030 | 0.061 | 1.80 | 3.67 | 108.0 | 220.0 |
| 15 (DN15) SF | 2.09 | 2.02 | 0.058 | 0.126 | 3.49 | 7.54 | 209.2 | 452.5 |
| 18 (DN15) LF | 0.55 | 0.49 | 0.015 | 0.031 | 0.91 | 1.84 | 54.7 | 110.5 |
| 18 (DN15) SF | 2.09 | 2.02 | 0.058 | 0.126 | 3.49 | 7.54 | 209.2 | 452.5 |
| 22 (DN20) SF | 3.07 | 4.43 | 0.123 | 0.191 | 7.37 | 11.45 | 442.4 | 686.9 |
| 28 (DN25) SF | 6.19 | 6.07 | 0.172 | 0.377 | 10.32 | 22.61 | 619.2 | 1356.8 |
| 35 (DN32) SF | 13.13 | 11.10 | 0.365 | 0.690 | 21.89 | 41.38 | 1313.3 | 2482.6 |
| 42 (DN40) SF | 22.49 | 22.26 | 0.625 | 1.383 | 37.48 | 82.95 | 2248.9 | 4977.0 |
| 54 (DN50) SF | 28.19 | 42.46 | 1.180 | 1.751 | 70.77 | 105.07 | 4246.2 | 6304.3 |

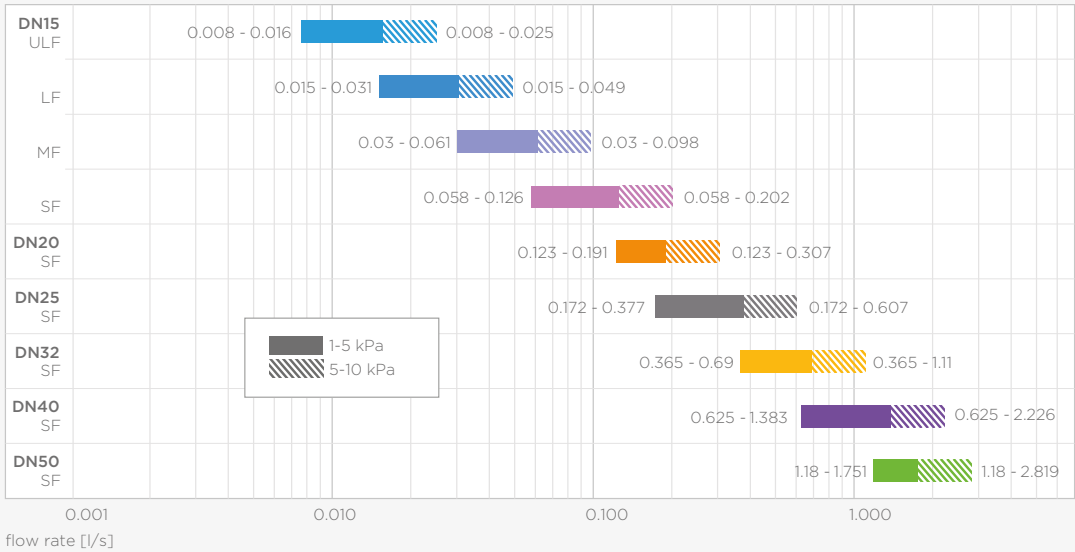

flow rate

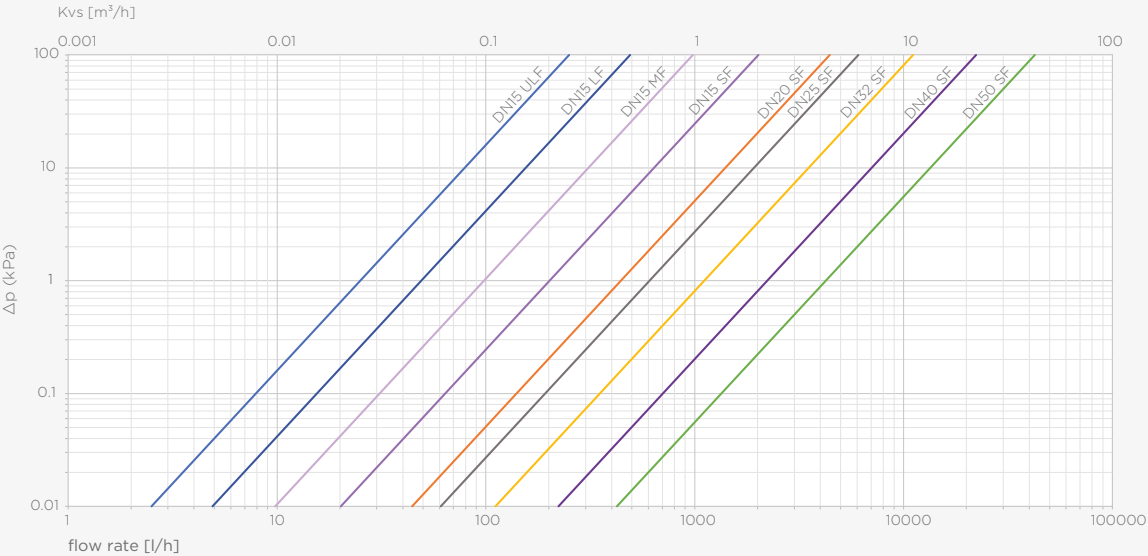

pressure loss

PSU1260 Pegler ProFlow static balancing valve
(2 x press, with union connection, inlet)

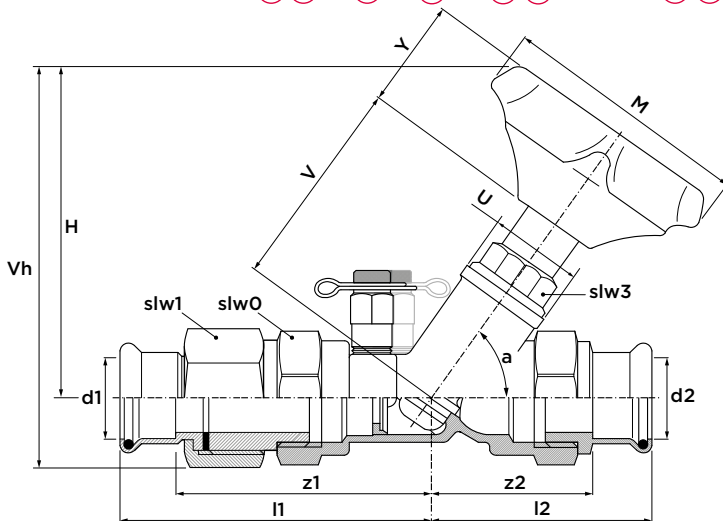
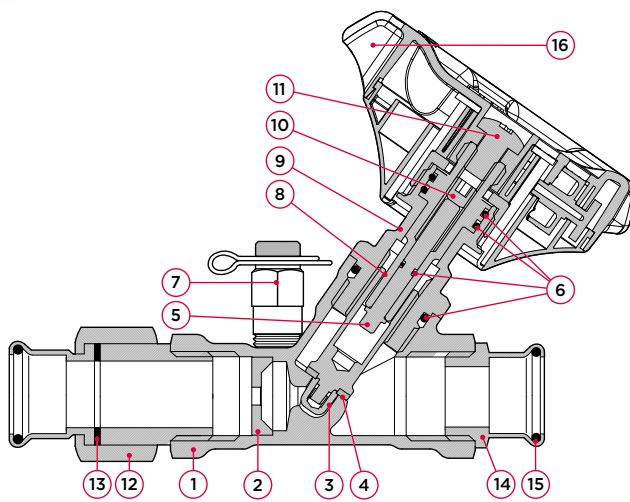

specifications

- max. operating pressure 16 bar
- operating temperature -10°C to 110°C
- VSH XPress gunmetal ends for carbon steel, stainless steel and copper tube
- fixed orifice measuring (FODRV)
- handle with visual digital positioning indicator
- memory stop for setting fixation
- test points for needle connection

| no. | component | material |
|-----|------------------|----------------------------|
| 1 | body | brass (CW511L) |
| 2 | orifice plate | brass (CW511L) |
| 3 | disc | brass (CW511L) |
| 4 | disc seal | PTFE |
| 5 | regulator pin | brass (CW511L) |
| 6 | o-rings | EPDM |
| 7 | test point | brass (CW602N) |
| 8 | spindle | brass (CW511L) |
| 9 | bonnet | brass (CW511L) |
| 10 | adjustment screw | brass (CW511L) |
| 11 | set screw | stainless steel (AISI 304) |
| 12 | union nut | gunmetal (CC499K) |
| 13 | flat seal | fiberring |
| 14 | end connection | gunmetal (CC499K) |
| 15 | o-ring | EPDM |
| 16 | handle | 30% glass filled PA 66 |

maximum pressure [bar]

| operating pressure | test pressure shell | test pressure seat |
|--------------------|---------------------|--------------------|
| 16 | 24 | 17.6 |

pressure equipment directive category

| | |
|----------------|-----|
| all dimensions | SEP |
|----------------|-----|

| dimension | article no. | weight [kg] | l1 | l2 | z1 | z2 | U [Ø] | V | Y | M | H | Vh | a [°] | slw0 | slw1 | slw3 |
|---------------|-------------|-------------|-----|-----|-----|----|-------|----|----|----|-----|-----|-------|------|------|------|
| 15 (DN15) ULF | 126293 | 0.55 | 79 | 59 | 59 | 39 | 27 | 32 | 38 | 90 | 92 | 107 | 55 | 28 | 32 | 25 |
| 15 (DN15) LF | 126247 | 0.55 | 79 | 59 | 59 | 39 | 27 | 32 | 38 | 90 | 92 | 107 | 55 | 28 | 32 | 25 |
| 15 (DN15) MF | 126291 | 0.55 | 79 | 59 | 59 | 39 | 27 | 32 | 38 | 90 | 92 | 107 | 55 | 28 | 32 | 25 |
| 15 (DN15) SF | 126248 | 0.55 | 79 | 59 | 59 | 39 | 27 | 32 | 38 | 90 | 92 | 107 | 55 | 28 | 32 | 25 |
| 18 (DN15) LF | 126249 | 0.55 | 74 | 60 | 54 | 40 | 27 | 32 | 38 | 90 | 92 | 107 | 55 | 28 | 32 | 25 |
| 18 (DN15) SF | 126250 | 0.55 | 74 | 60 | 54 | 40 | 27 | 32 | 38 | 90 | 92 | 107 | 55 | 28 | 32 | 25 |
| 22 (DN20) SF | 126251 | 0.67 | 87 | 66 | 66 | 45 | 27 | 38 | 38 | 90 | 96 | 114 | 55 | 32 | 32 | 25 |
| 28 (DN25) SF | 126252 | 0.99 | 95 | 78 | 72 | 55 | 33 | 45 | 38 | 90 | 108 | 131 | 55 | 41 | 39 | 25 |
| 32 (DN32) SF | 126253 | 1.59 | 105 | 95 | 79 | 69 | 41 | 56 | 38 | 90 | 126 | 154 | 55 | 50 | 50 | 32 |
| 40 (DN40) SF | 126254 | 2.05 | 116 | 103 | 86 | 73 | 60 | 62 | 38 | 90 | 132 | 163 | 55 | 55 | 55 | 35 |
| 50 (DN50) SF | 126255 | 3.36 | 142 | 130 | 107 | 95 | 58 | 74 | 38 | 90 | 151 | 189 | 55 | 70 | 70 | 35 |

| dimension | Kv [m³/h] | Kvs [m³/h] | flow [l/s] | | flow [l/min] | | flow [l/h] | |
|---------------|-----------|------------|------------|-------|--------------|--------|------------|--------|
| | | | min. | max. | min. | max. | min. | max. |
| 15 (DN15) ULF | 0.27 | 0.25 | 0.008 | 0.016 | 0.46 | 0.94 | 27.4 | 56.2 |
| 15 (DN15) LF | 0.55 | 0.49 | 0.015 | 0.031 | 0.91 | 1.84 | 54.7 | 110.5 |
| 15 (DN15) MF | 1.08 | 0.98 | 0.030 | 0.061 | 1.80 | 3.67 | 108.0 | 220.0 |
| 15 (DN15) SF | 2.09 | 2.02 | 0.058 | 0.126 | 3.49 | 7.54 | 209.2 | 452.5 |
| 18 (DN15) LF | 0.55 | 0.49 | 0.015 | 0.031 | 0.91 | 1.84 | 54.7 | 110.5 |
| 18 (DN15) SF | 2.09 | 2.02 | 0.058 | 0.126 | 3.49 | 7.54 | 209.2 | 452.5 |
| 22 (DN20) SF | 3.07 | 4.43 | 0.123 | 0.191 | 7.37 | 11.45 | 442.4 | 686.9 |
| 28 (DN25) SF | 6.19 | 6.07 | 0.172 | 0.377 | 10.32 | 22.61 | 619.2 | 1356.8 |
| 32 (DN32) SF | 13.13 | 11.10 | 0.365 | 0.690 | 21.89 | 41.38 | 1313.3 | 2482.6 |
| 40 (DN40) SF | 22.49 | 22.26 | 0.625 | 1.383 | 37.48 | 82.95 | 2248.9 | 4977.0 |
| 50 (DN50) SF | 28.19 | 42.46 | 1.180 | 1.751 | 70.77 | 105.07 | 4246.2 | 6304.3 |

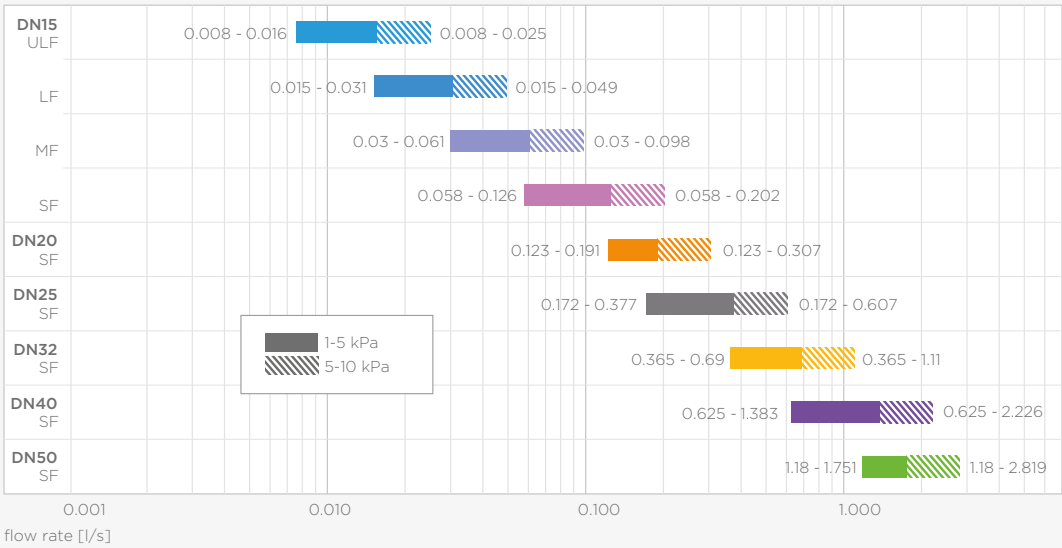

flow rate

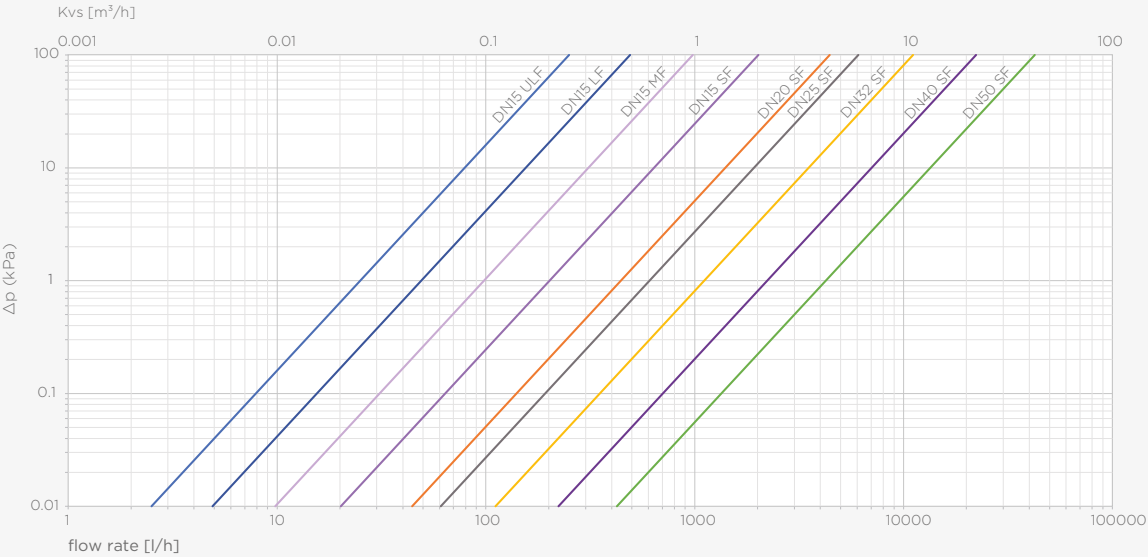

pressure loss

PP1260 Pegler ProFlow static balancing valve
(2 x press)

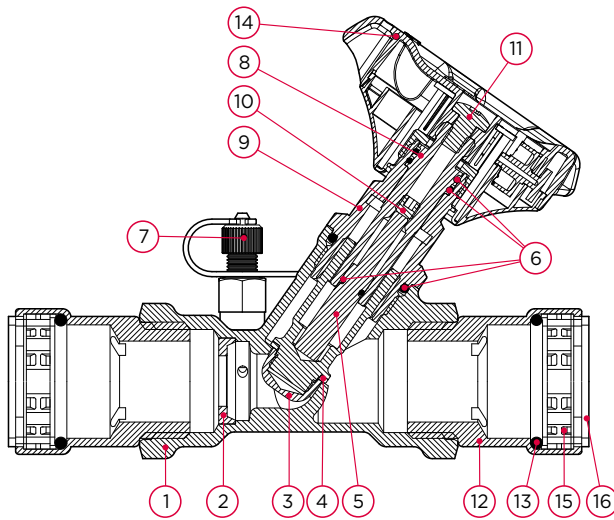

specifications

- max. operating pressure 16 bar
- operating temperature -10°C to 120°C
- VSH PowerPress connections for thick wall steel tube
- fixed orifice measuring (FODRV)
- handle with visual digital positioning indicator
- memory stop for setting fixation
- test points for needle connection
- socket transport protection
- visual press indicators

| no. | component | material |
|-----|------------------|---------------------------------|
| 1 | body | brass (CW511L) |
| 2 | orifice plate | brass (CW511L) |
| 3 | disc | brass (CW511L) |
| 4 | disc seal | PTFE |
| 5 | regulator pin | brass (CW511L) |
| 6 | o-rings | EPDM |
| 7 | test point | DZR brass (CW602N) |
| 8 | spindle | brass (CW511L) |
| 9 | bonnet | brass (CW511L) |
| 10 | adjustment screw | brass (CW511L) |
| 11 | set screw | stainless steel (AISI 304) |
| 12 | press end | carbon steel zinc nickel plated |
| 13 | o-ring | EPDM |
| 14 | handle | 30% glass filled PA 66 |
| 15 | grab ring | stainless steel |

maximum pressure [bar]

| operating pressure | test pressure shell | test pressure seat |
|--------------------|---------------------|--------------------|
| 16 | 24 | 17.6 |

pressure equipment directive category

| | |
|----------------|-----|
| all dimensions | SEP |
|----------------|-----|

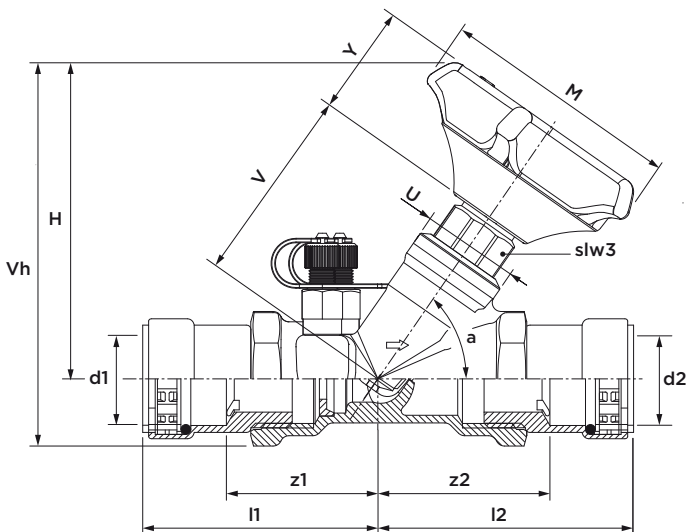

| dimension | article no. | weight [kg] | l1 | l2 | z1 | z2 | U [Ø] | V | Y | M | H | Vh | a [°] | slw3 |
|---------------|-------------|-------------|-----|-----|----|----|-------|-----|----|----|-----|-----|-------|------|
| ½" (DN15) LF | PWR9440486 | 0.68 | 73 | 75 | 46 | 48 | 27 | 64 | 38 | 90 | 92 | 107 | 55 | 25 |
| ½" (DN15) SF | PWR9440497 | 0.68 | 73 | 75 | 46 | 48 | 27 | 64 | 38 | 90 | 92 | 107 | 55 | 25 |
| ¾" (DN20) SF | PWR9440508 | 0.80 | 74 | 83 | 43 | 52 | 27 | 64 | 38 | 90 | 96 | 114 | 55 | 25 |
| 1" (DN25) SF | PWR9440519 | 1.15 | 88 | 96 | 53 | 60 | 33 | 73 | 38 | 90 | 108 | 131 | 55 | 25 |
| 1¼" (DN32) SF | PWR9440521 | 1.93 | 110 | 126 | 62 | 78 | 41 | 81 | 38 | 90 | 126 | 154 | 55 | 32 |
| 1½" (DN40) SF | PWR9440530 | 2.52 | 114 | 129 | 66 | 81 | 60 | 85 | 38 | 90 | 132 | 163 | 55 | 35 |
| 2" (DN50) SF | PWR9440541 | 4.02 | 133 | 149 | 80 | 96 | 58 | 103 | 38 | 90 | 151 | 189 | 55 | 35 |

| dimension | Kv [m ³ /h] | Kvs [m ³ /h] | flow [l/s] | | flow [l/min] | | flow [l/h] | |
|---------------|------------------------|-------------------------|------------|-------|--------------|--------|------------|--------|
| | | | min. | max. | min. | max. | min. | max. |
| ½" (DN15) LF | 0.55 | 0.49 | 0.015 | 0.031 | 0.91 | 1.84 | 54.7 | 110.5 |
| ½" (DN12) SF | 2.09 | 2.02 | 0.058 | 0.126 | 3.49 | 7.54 | 209.2 | 452.5 |
| ¾" (DN20) SF | 3.07 | 4.43 | 0.123 | 0.191 | 7.37 | 11.45 | 442.4 | 686.9 |
| 1" (DN25) SF | 6.19 | 6.07 | 0.172 | 0.377 | 10.32 | 22.61 | 619.2 | 1356.8 |
| 1¼" (DN32) SF | 13.13 | 11.10 | 0.365 | 0.690 | 21.89 | 41.38 | 1313.3 | 2482.6 |
| 1½" (DN40) SF | 22.49 | 22.26 | 0.625 | 1.383 | 37.48 | 82.95 | 2248.9 | 4977.0 |
| 2" (DN50) SF | 28.19 | 42.46 | 1.180 | 1.751 | 70.77 | 105.07 | 4246.2 | 6304.3 |

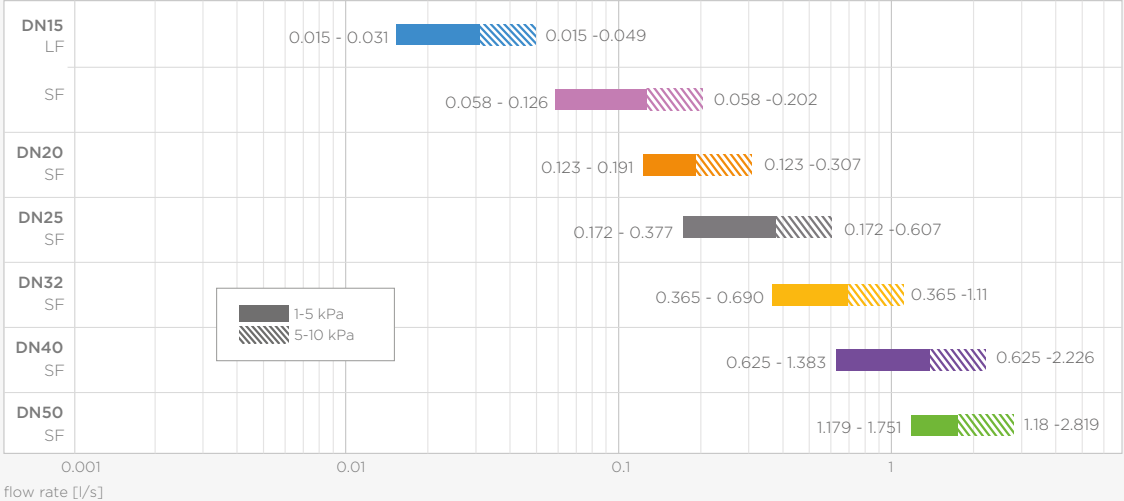

flow rate

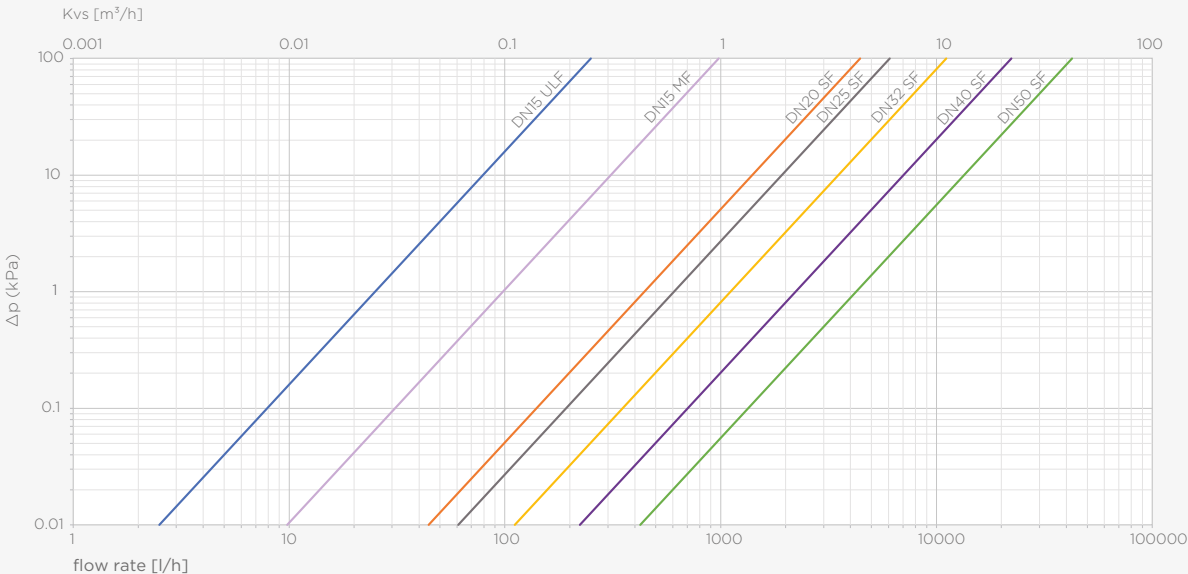

pressure loss

V955 Pegler ProFlow static balancing valve PN16
(2 x flange)

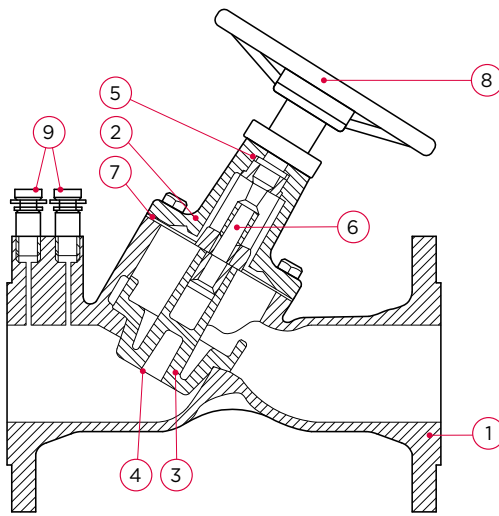

specifications

- max. operating pressure 16 bar
- operating temperature -10°C to 120°C
- fixed orifice
- regulating and isolating functions
- face to face dimensions to EN558-1
- DZR brass test points for flow measurement
- lockable settings

| no. | component | material |
|-----|---------------------|---|
| 1 | body | ductile iron (EN-GJS-400-15) |
| 2 | bonnet | ductile iron (EN-GJS-400-15) |
| 3 | disc | ductile iron (EN-GJS-400-15), EPDM coated |
| 4 | disc nail | brass |
| 5 | o-ring | EPDM |
| 6 | stem | stainless steel |
| 7 | gasket | graphite |
| 8 | handwheel DN50-100 | carbon steel |
| | handwheel DN125-300 | ductile iron (EN-GJS-400-15) |
| 9 | test points | DZR brass (CW602N) |

maximum pressure [bar]

| operating pressure | test pressure shell | test pressure seat |
|--------------------|---------------------|--------------------|
| 16 | 24 | 17.6 |

pressure equipment directive category

| | |
|----------------|-----|
| all dimensions | SEP |
|----------------|-----|

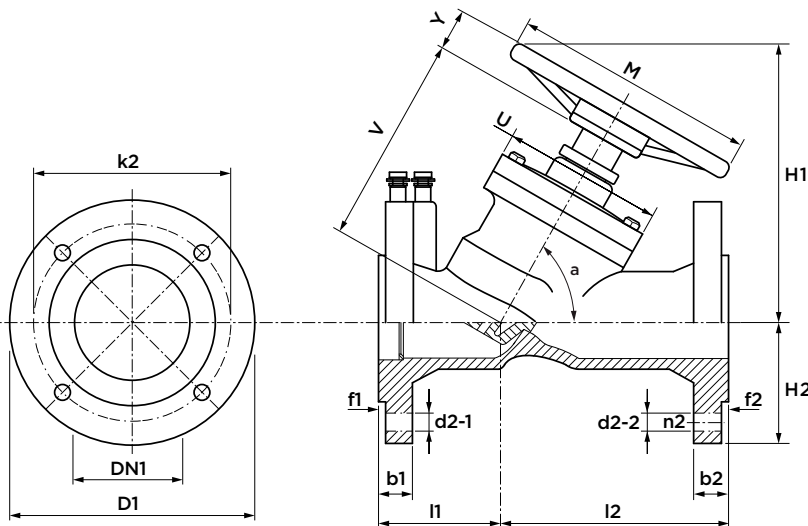

| dimension | article no. | weight [kg] | D1 | d2-1/d2-2 | b1/b2 | f1/f2 | l1 | l2 | U [Ø] | V | Y | M | H1 | H2 | n2 | k2 | a [°] |
|-----------|-------------|-------------|-----|-----------|-------|-------|-----|-----|-------|-----|----|-----|-----|-----|----|-----|-------|
| DN65 | 150013 | 17.0 | 185 | 19 | 20 | 3 | 73 | 218 | 122 | 192 | 15 | 172 | 263 | 93 | 4 | 145 | 55 |
| DN80 | 150014 | 20.0 | 200 | 19 | 20 | 3 | 84 | 226 | 130 | 198 | 15 | 172 | 268 | 100 | 8 | 160 | 55 |
| DN100 | 150010 | 29.0 | 220 | 20 | 22 | 3 | 98 | 252 | 141 | 223 | 15 | 197 | 300 | 110 | 8 | 180 | 55 |
| DN125 | 150011 | 40.0 | 250 | 20 | 22 | 3 | 115 | 286 | 154 | 242 | 15 | 229 | 328 | 125 | 8 | 210 | 55 |
| DN150 | 150012 | 52.0 | 285 | 20 | 24 | 3 | 127 | 353 | 167 | 255 | 15 | 261 | 340 | 143 | 8 | 240 | 55 |
| DN200 | 150015 | 113.0 | 340 | 21 | 26 | 3 | 160 | 440 | 192 | 420 | 15 | 324 | 525 | 170 | 12 | 295 | 55 |
| DN250 | 150016 | 185.0 | 400 | 21 | 29 | 3 | 169 | 561 | 218 | 449 | 15 | 387 | 572 | 200 | 12 | 355 | 55 |
| DN300 | 150017 | 248.0 | 455 | 22 | 32 | 4 | 199 | 651 | 243 | 581 | 15 | 450 | 686 | 228 | 12 | 410 | 55 |

| dimension | Kv [m³/h] | Kvs [m³/h] | flow [l/s] | | flow [l/min] | | flow [l/h] | |
|-----------|-----------|------------|------------|---------|--------------|---------|------------|----------|
| | | | min. | max. | min. | max. | min. | max. |
| DN65 | 80 | 104 | 2.890 | 5.210 | 173.40 | 312.60 | 10404.0 | 18756.0 |
| DN80 | 114 | 116 | 3.320 | 7.210 | 199.20 | 432.60 | 11952.0 | 25956.0 |
| DN100 | 149 | 213 | 5.920 | 11.100 | 355.20 | 666.00 | 21312.0 | 39960.0 |
| DN125 | 261 | 333 | 9.250 | 16.940 | 555.00 | 1016.40 | 33300.0 | 60984.0 |
| DN150 | 371 | 476 | 13.220 | 23.600 | 793.20 | 1416.00 | 47592.0 | 84960.0 |
| DN200 | 339 | 768 | 21.330 | 37.760 | 1279.80 | 2265.60 | 76788.0 | 135936.0 |
| DN250 | 832 | 1153 | 35.890 | 71.620 | 2153.40 | 4297.20 | 129204.0 | 257832.0 |
| DN300 | 873 | 1743 | 49.750 | 108.260 | 2985.00 | 6495.60 | 179100.0 | 389736.0 |

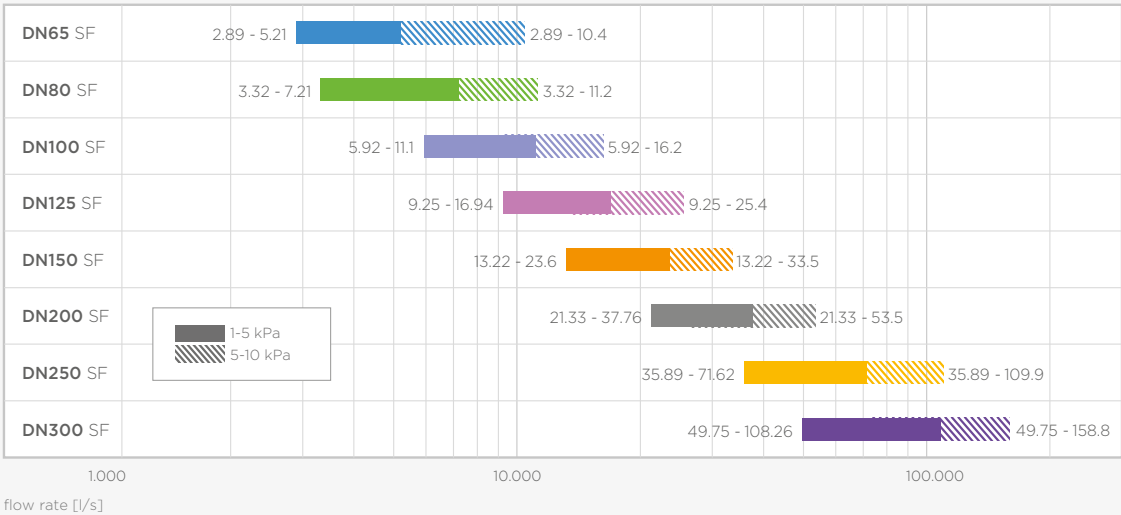

flow rate

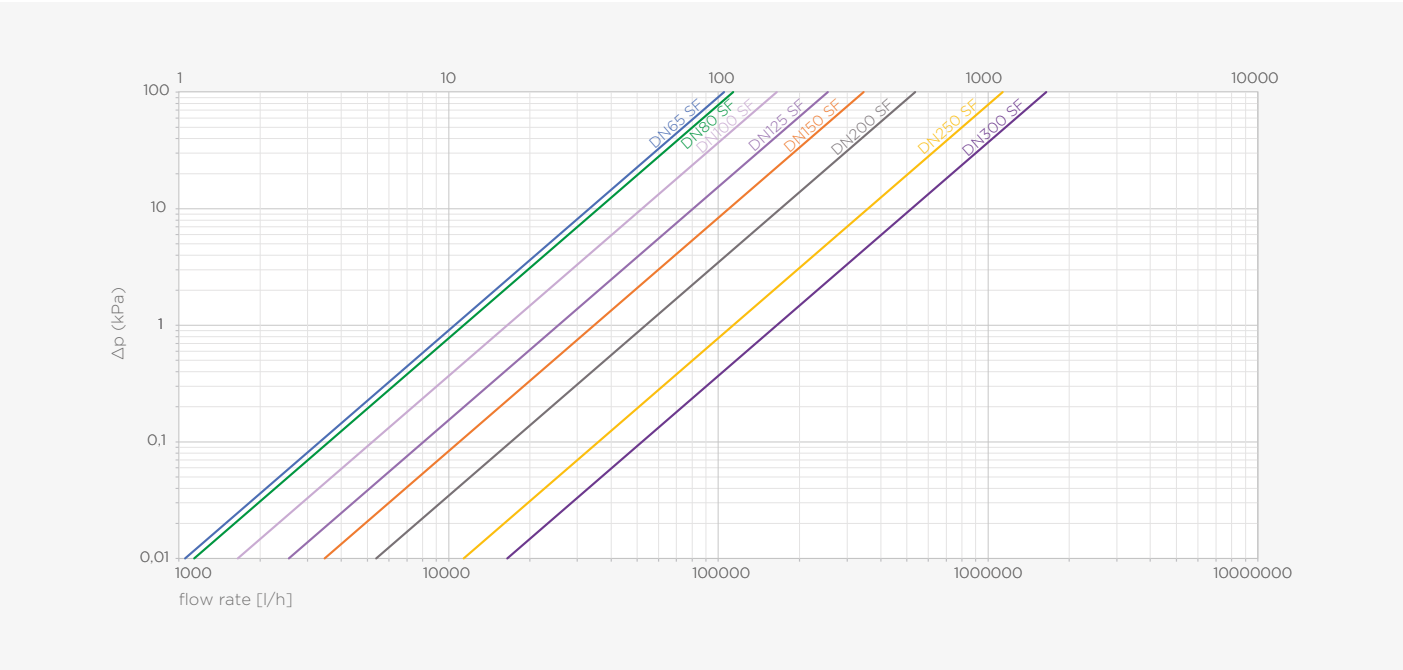

pressure loss

1600 Pegler ProFlow pressure independent control valve (2 x female thread)

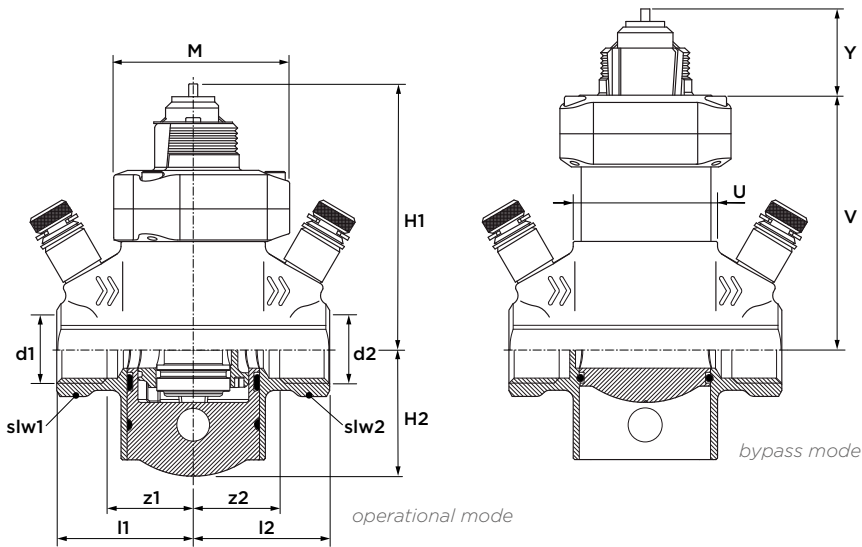
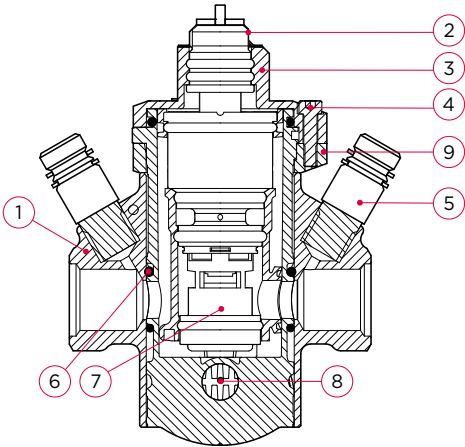

specifications

- max. operating pressure 16 bar
- operating temperature -10°C to 90°C
- built-in bypass: full bore forward and backflush
- built in isolation mode

| no. | component | material |
|-----|--------------|------------------------------|
| 1 | body | brass (CW511L) |
| 2 | indicator | stainless steel (AISI 304) |
| 3 | cap | brass (CW511L) |
| 4 | socket screw | stainless steel (AISI 304) |
| 5 | test point | brass (CW602N) |
| 6 | o-ring | EPDM |
| 7 | cartridge | polyphenylene Sulphide (PPS) |
| 8 | locking peg | polyoxymethylene (POM) |
| 9 | clamp | brass (CW511L) |

maximum pressure [bar]

| operating pressure | test pressure shell | test pressure seat |
|--------------------|---------------------|--------------------|
| 16 | 24 | 17.6 |

pressure equipment directive category

| | |
|----------------|-----|
| all dimensions | SEP |
|----------------|-----|

| dimension | article no. | weight [kg] | l1/l2 | z1/z2 | U [Ø] | V | Y | M | H1 | H2 | slw1/sl2 |
|---------------|-------------|-------------|-------|-------|-------|-----|----|----|-----|----|----------|
| G½" (DN15) LF | 16001 | 0.90 | 48 | 29 | 49 | 84 | 31 | 65 | 90 | 44 | 27 |
| G½" (DN15) SF | 16002 | 0.90 | 48 | 29 | 49 | 84 | 31 | 65 | 90 | 44 | 27 |
| G½" (DN15) HF | 16003 | 0.90 | 48 | 29 | 49 | 84 | 31 | 65 | 90 | 44 | 27 |
| G¾" (DN20) SF | 16004 | 1.50 | 52 | 33 | 60 | 107 | 31 | 76 | 105 | 58 | 32 |
| G¾" (DN20) HF | 16005 | 1.50 | 52 | 33 | 60 | 107 | 31 | 76 | 105 | 58 | 32 |
| G1" (DN25) SF | 16006 | 1.50 | 58 | 42 | 60 | 107 | 31 | 76 | 105 | 58 | 40 |

| dimension | flow [l/s] | | flow [l/min] | | flow [l/h] | |
|---------------|------------|-------|--------------|-------|------------|--------|
| | min. | max. | min. | max. | min. | max. |
| G½" (DN15) LF | 0.010 | 0.037 | 0.60 | 2.22 | 36.0 | 133.2 |
| G½" (DN15) SF | 0.022 | 0.160 | 1.32 | 9.60 | 79.2 | 576.0 |
| G½" (DN15) HF | 0.078 | 0.340 | 4.68 | 20.40 | 280.8 | 1224.0 |
| G¾" (DN20) SF | 0.100 | 0.250 | 6.00 | 15.00 | 360.0 | 900.0 |
| G¾" (DN20) HF | 0.250 | 0.560 | 15.00 | 33.60 | 900.0 | 2016.0 |
| G1" (DN25) SF | 0.260 | 0.580 | 15.60 | 34.80 | 936.0 | 2088.0 |

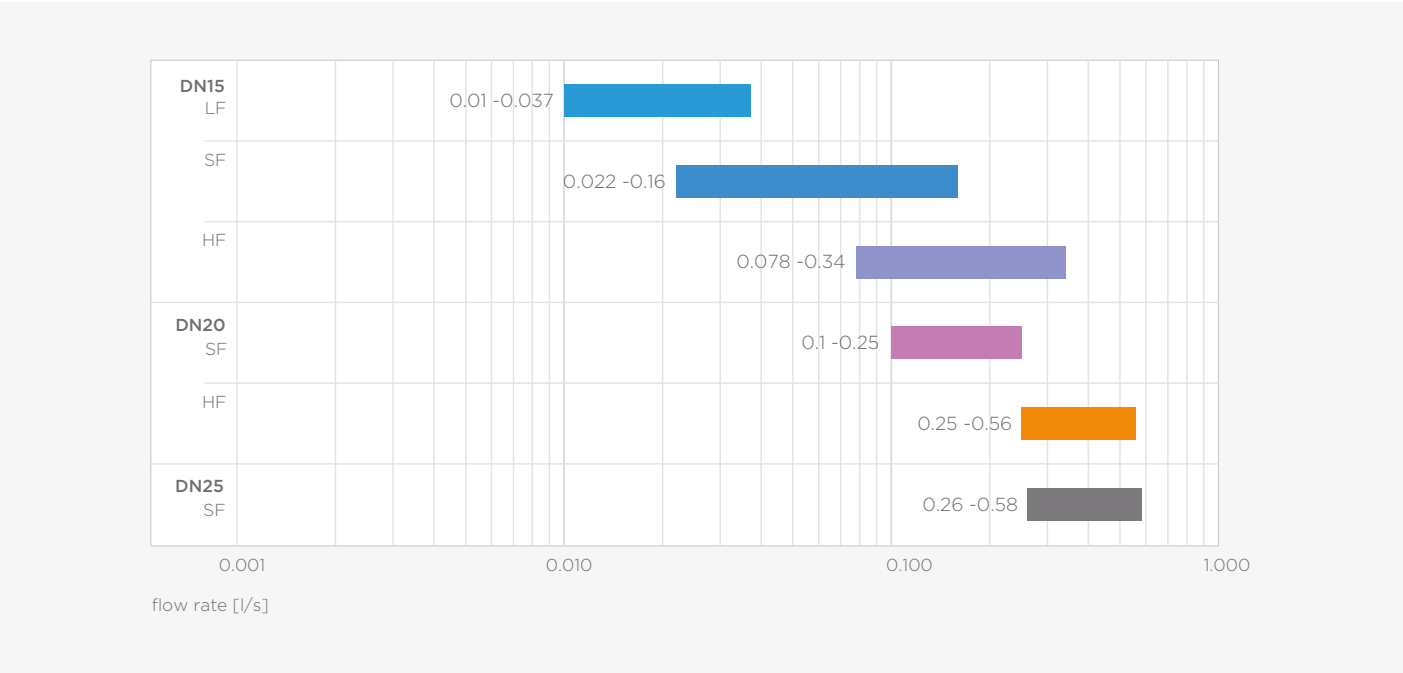

flow rate

PS1600 Pegler ProFlow pressure independent control valve
(2 x press)

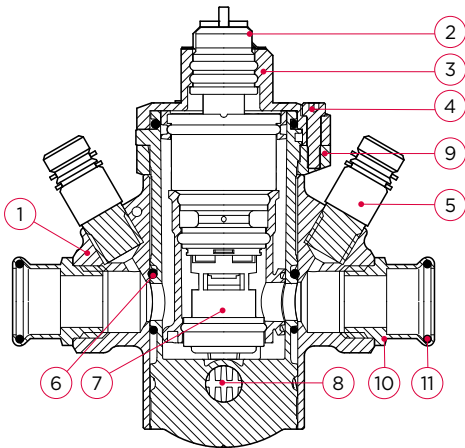

specifications

- max. operating pressure 16 bar
- operating temperature -10°C to 90°C
- built-in bypass: full bore forward and backflush
- built in isolation mode
- VSH XPress ends for copper, carbon steel and stainless steel tube

| no. | component | material |
|-----|----------------|------------------------------|
| 1 | body | brass (CW511L) |
| 2 | indicator | stainless steel (AISI 304) |
| 3 | cap | brass (CW511L) |
| 4 | socket screw | stainless steel (AISI 304) |
| 5 | test point | brass (CW602N) |
| 6 | o-ring | EPDM |
| 7 | cartridge | polyphenylene Sulphide (PPS) |
| 8 | bocking peg | polyoxymethylene (POM) |
| 9 | clamp | brass (CW511L) |
| 10 | end connection | gunmetal (CC499K) |
| 11 | o-ring | EPDM |

maximum pressure [bar]

| operating pressure | test pressure shell | test pressure seat |
|--------------------|---------------------|--------------------|
| 16 | 24 | 17,6 |

pressure equipment directive category

| | |
|----------------|-----|
| all dimensions | SEP |
|----------------|-----|

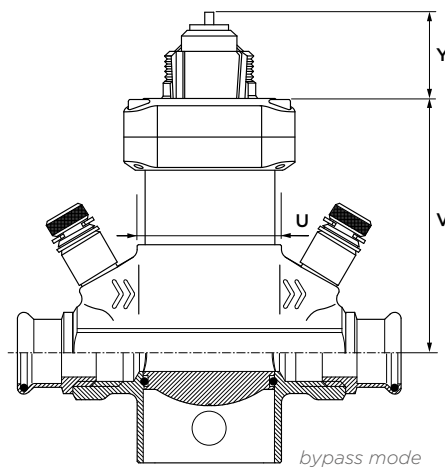
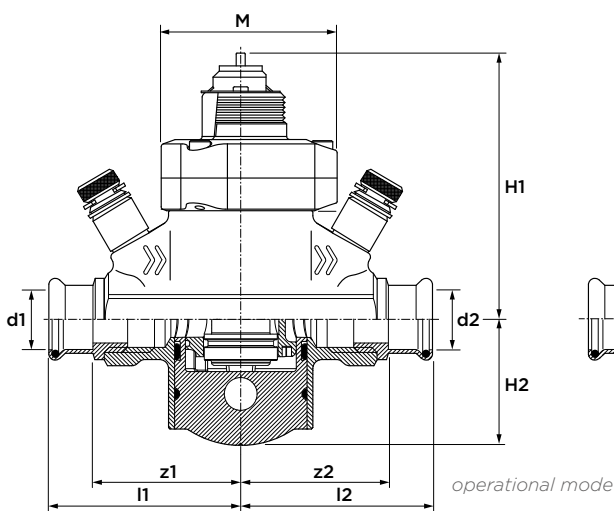

| dimension | article no. | weight [kg] | l1/l2 | z1/z2 | U [Ø] | V | Y | M | H1 | H2 |
|--------------|-------------|-------------|-------|-------|-------|-----|----|----|-----|----|
| 15 (DN15) LF | 16020 | 0.96 | 68 | 48 | 49 | 84 | 31 | 65 | 90 | 44 |
| 15 (DN15) SF | 16021 | 0.96 | 68 | 48 | 49 | 84 | 31 | 65 | 90 | 44 |
| 15 (DN15) HF | 16022 | 0.96 | 68 | 48 | 49 | 84 | 31 | 65 | 90 | 44 |
| 22 (DN20) SF | 16023 | 1.64 | 76 | 55 | 60 | 107 | 31 | 76 | 105 | 58 |
| 22 (DN20) HF | 16024 | 1.64 | 76 | 55 | 60 | 107 | 31 | 76 | 105 | 58 |
| 28 (DN25) SF | 16025 | 1.64 | 84 | 61 | 60 | 107 | 31 | 76 | 105 | 58 |

| dimension | flow [l/s] | | flow [l/min] | | flow [l/h] | |
|--------------|------------|-------|--------------|-------|------------|--------|
| | min. | max. | min. | max. | min. | max. |
| 15 (DN15) LF | 0.010 | 0.037 | 0.60 | 2.22 | 36.0 | 133.2 |
| 15 (DN15) SF | 0.022 | 0.160 | 1.32 | 9.60 | 79.2 | 576.0 |
| 15 (DN15) HF | 0.078 | 0.340 | 4.68 | 20.40 | 280.8 | 1224.0 |
| 22 (DN20) SF | 0.100 | 0.250 | 6.00 | 15.00 | 360.0 | 900.0 |
| 22 (DN20) HF | 0.250 | 0.560 | 15.00 | 33.60 | 900.0 | 2016.0 |
| 28 (DN25) SF | 0.260 | 0.580 | 15.60 | 34.80 | 936.0 | 2088.0 |

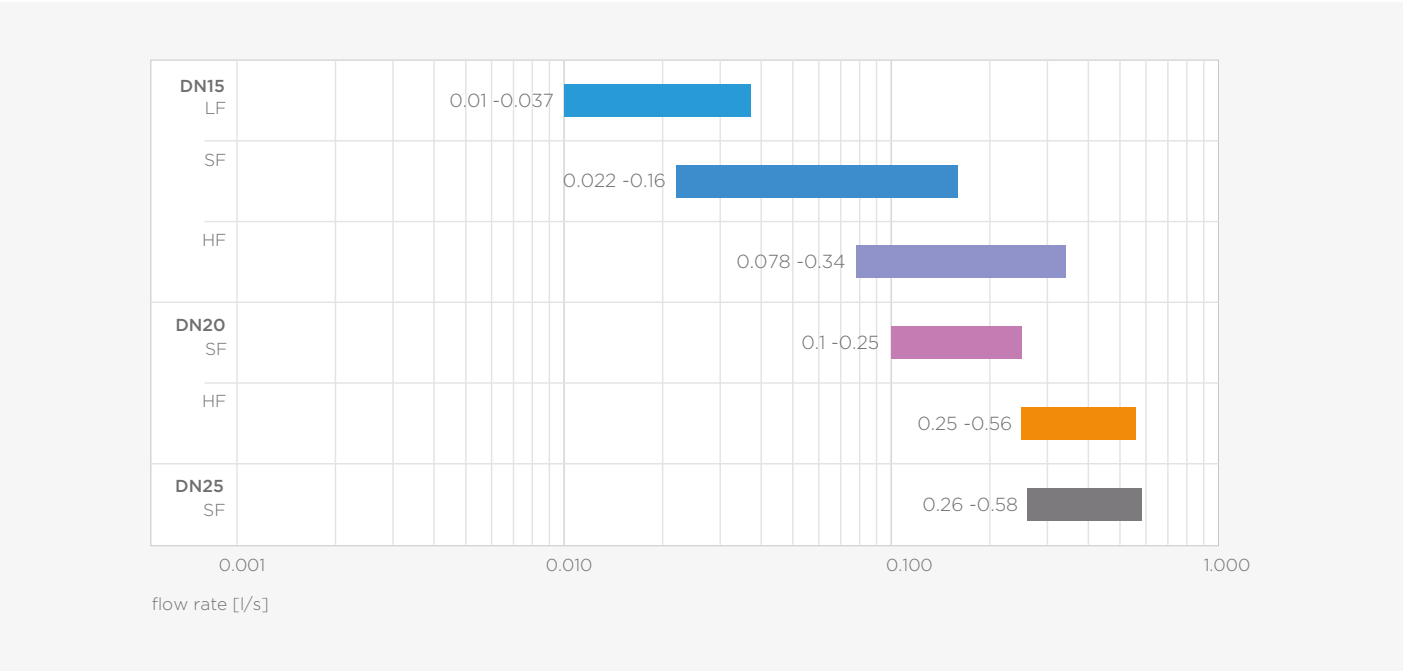

flow rate

PSU1600 Pegler ProFlow pressure independent control valve

(2 x press, with union connection, inlet)



specifications

- max. operating pressure 16 bar
- operating temperature -10°C to 90°C
- built-in bypass: full bore forward and backflush
- built in isolation mode
- VSH XPress ends for copper, carbon steel and stainless steel tube

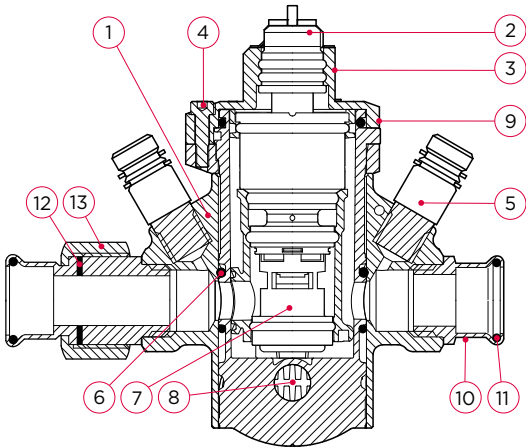

| no. | component | material |
|-----|----------------|------------------------------|
| 1 | body | brass (CW511L) |
| 2 | indicator | stainless steel (AISI 304) |
| 3 | cap | brass (CW511L) |
| 4 | socket screw | stainless steel (AISI 304) |
| 5 | test point | brass (CW602N) |
| 6 | o-ring | EPDM |
| 7 | cartridge | polyphenylene Sulphide (PPS) |
| 8 | locking peg | polyoxymethylene (POM) |
| 9 | clamp | brass (CW511L) |
| 10 | end connection | gunmetal (CC499K) |
| 11 | o-ring | EPDM |
| 12 | flat seal | fiberring |
| 13 | union nut | gunmetal (CC499K) |

maximum pressure [bar]

| operating pressure | test pressure shell | test pressure seat |
|--------------------|---------------------|--------------------|
| 16 | 24 | 17,6 |

pressure equipment directive category

| | |
|----------------|-----|
| all dimensions | SEP |
|----------------|-----|

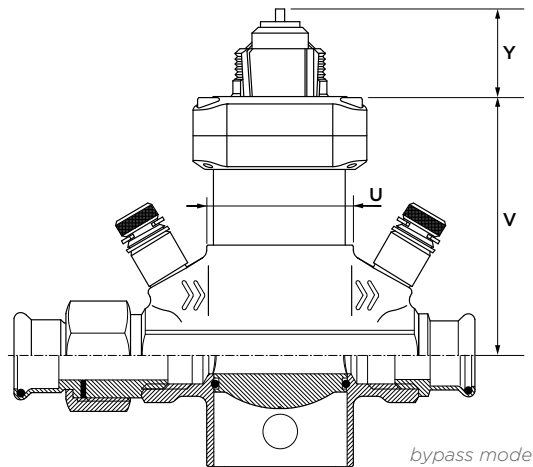
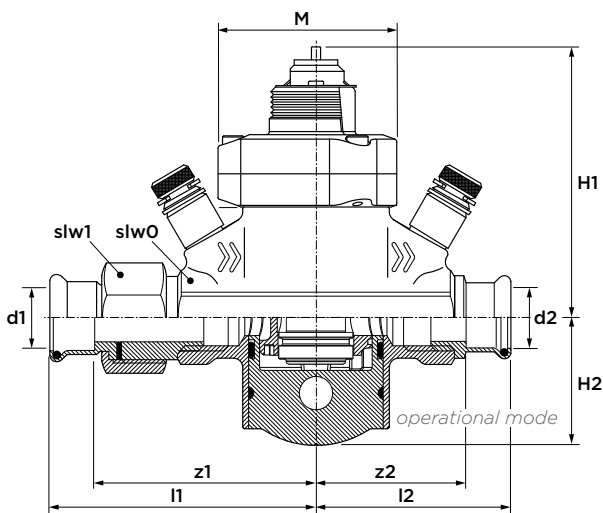

| dimension | article no. | weight [kg] | l1 | l2 | z1 | z2 | U [Ø] | V | Y | M | H1 | H2 | slw0 | slw2 |
|--------------|-------------|-------------|----|-----|----|----|-------|-----|----|----|-----|----|------|------|
| 15 (DN15) LF | 16050 | 0.96 | 68 | 89 | 48 | 70 | 49 | 84 | 31 | 65 | 90 | 44 | 27 | 34 |
| 15 (DN15) SF | 16051 | 0.96 | 68 | 89 | 48 | 70 | 49 | 84 | 31 | 65 | 90 | 44 | 27 | 34 |
| 15 (DN15) HF | 16052 | 0.96 | 68 | 89 | 48 | 70 | 49 | 84 | 31 | 65 | 90 | 44 | 27 | 34 |
| 22 (DN20) SF | 16053 | 1.64 | 75 | 105 | 55 | 84 | 60 | 107 | 31 | 76 | 105 | 58 | 32 | 40 |
| 22 (DN20) HF | 16054 | 1.64 | 75 | 105 | 55 | 84 | 60 | 107 | 31 | 76 | 105 | 58 | 32 | 40 |
| 28 (DN25) SF | 16055 | 1.64 | 84 | 109 | 62 | 86 | 60 | 107 | 31 | 76 | 105 | 58 | 40 | 48 |

| dimension | flow [l/s] | | flow [l/min] | | flow [l/h] | |
|--------------|------------|-------|--------------|-------|------------|--------|
| | min. | max. | min. | max. | min. | max. |
| 15 (DN15) LF | 0.010 | 0.037 | 0.60 | 2.22 | 36.0 | 133.2 |
| 15 (DN15) SF | 0.022 | 0.160 | 1.32 | 9.60 | 79.2 | 576.0 |
| 15 (DN15) HF | 0.078 | 0.340 | 4.68 | 20.40 | 280.8 | 1224.0 |
| 22 (DN20) SF | 0.100 | 0.250 | 6.00 | 15.00 | 360.0 | 900.0 |
| 22 (DN20) HF | 0.250 | 0.560 | 15.00 | 33.60 | 900.0 | 2016.0 |
| 28 (DN25) SF | 0.260 | 0.580 | 15.60 | 34.80 | 936.0 | 2088.0 |

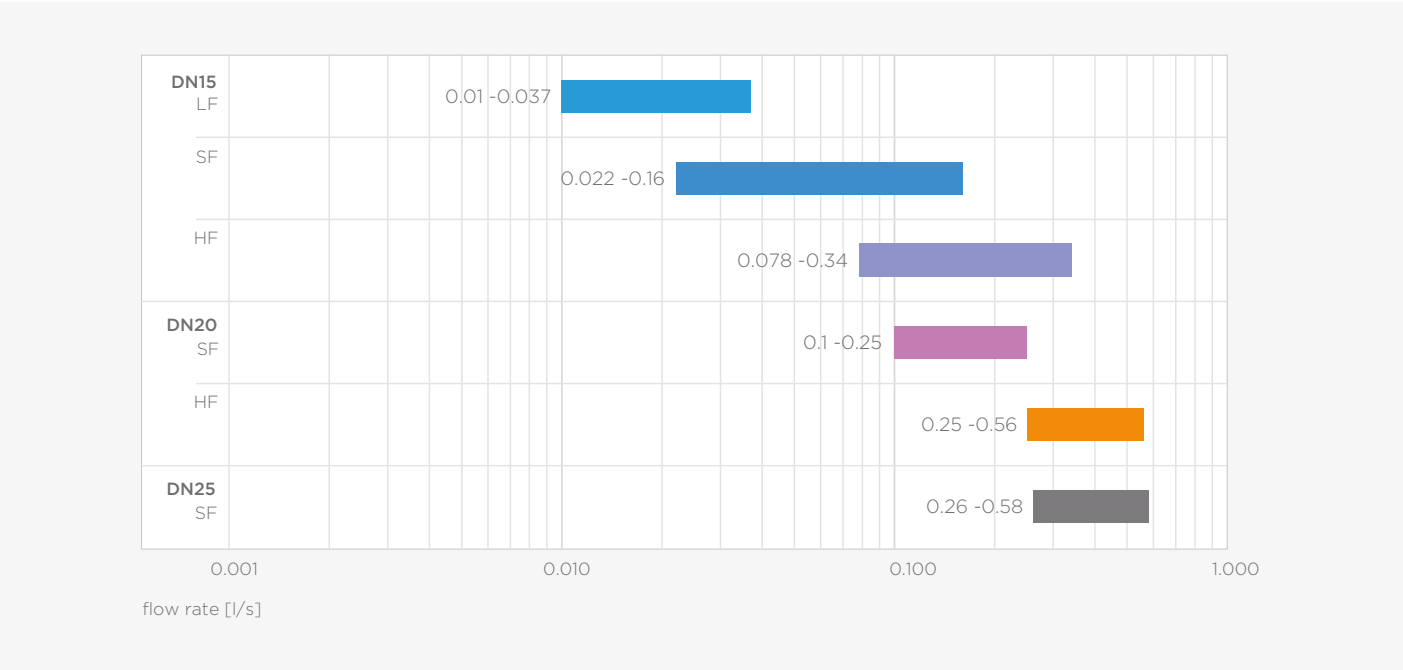

flow rate

1500 Pegler ProFlow pressure independent control valve (2 x female thread)

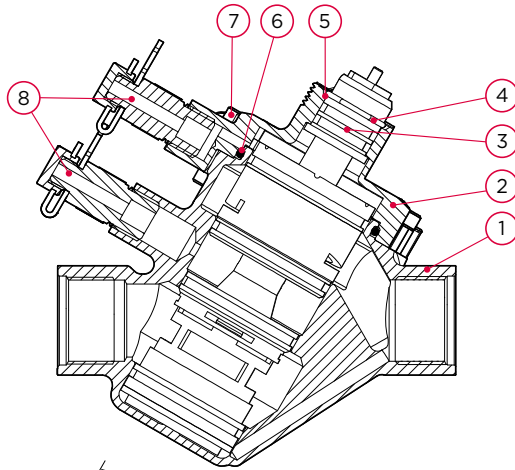

specifications

- built in direct flow measurement with venturi technology
- clear visual indicator for settings
- new Fast Flush cap for simplified access to cartridge and flushing
- VSH XPress connections for copper, carbon steel and stainless steel tube
- differential pressure control range 30-400 kPa
- on/off control characteristic

| no. | component | material |
|-----|--------------|--|
| 1 | body | DN15-25: brass (CW511L) DN32-50: brass (CC770S lead-free) |
| 2 | cap | DN15-25: brass (CW511L) DN32-50: brass (CC770S lead-free) |
| 3 | cartridge | polyphenylene sulphide (PPS) |
| 4 | spring clip | stainless steel (302526) |
| 5 | indicator | stainless steel (AISI 304) |
| 6 | o-ring | EPDM (EP1/1/5) |
| 7 | socket screw | stainless steel (A2-70) |
| 8 | test point | brass (CW602N) |

maximum pressure [bar]

| operating pressure | test pressure shell | test pressure seat |
|--------------------|---------------------|--------------------|
| 25 | 37.5 | n/a |

pressure equipment directive category

| | |
|-----------|-----|
| all sizes | SEP |
|-----------|-----|

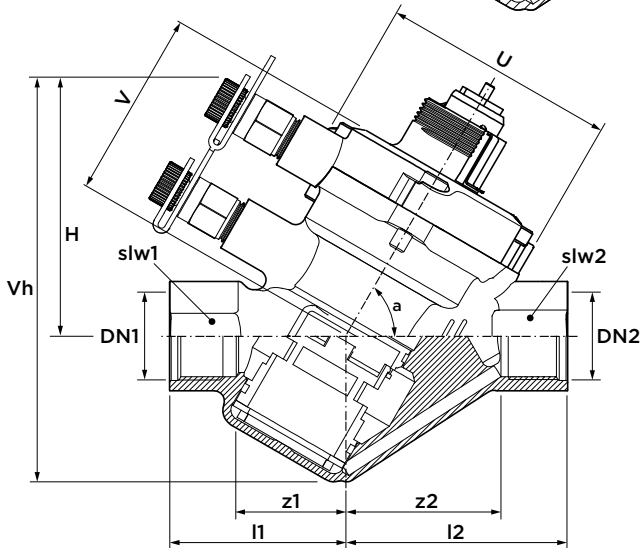

| dimension | article no. | weight [kg] | l1 | l2 | z1 | z2 | H | V | U [Ø] | a [°] | slw1/sl2 | Vh |
|----------------|-------------|-------------|----|-----|----|----|-----|-----|-------|-------|----------|-----|
| G½" (DN15) LF | 15112 | 0.677 | 45 | 57 | 25 | 37 | 69 | 45 | 68 | 60 | 28 | 104 |
| G½" (DN15) SF | 15113 | 0.677 | 45 | 58 | 25 | 37 | 69 | 45 | 68 | 60 | 28 | 104 |
| G½" (DN15) HF | 15114 | 0.677 | 45 | 59 | 25 | 37 | 69 | 45 | 68 | 60 | 28 | 104 |
| G¾" (DN20) SF | 15115 | 1.066 | 53 | 67 | 33 | 47 | 78 | 57 | 81 | 60 | 34 | 122 |
| G¾" (DN20) HF | 15116 | 1.066 | 53 | 67 | 33 | 47 | 78 | 57 | 81 | 60 | 34 | 122 |
| G1" (DN25) SF | 15117 | 1.587 | 59 | 83 | 37 | 53 | 89 | 65 | 108 | 60 | 41 | 132 |
| G¾" (DN25) HF | 15118 | 1.587 | 59 | 83 | 37 | 53 | 89 | 65 | 108 | 60 | 41 | 132 |
| G1¼" (DN32) HF | 15119 | 2.103 | 69 | 90 | 44 | 64 | 102 | 77 | 124 | 60 | 50 | 156 |
| G1¼" (DN40) SF | 15272 | 3.652 | 78 | 112 | 54 | 87 | 129 | 107 | 162 | 60 | 57 | 195 |
| G2" (DN50) HF | 15273 | 4.093 | 86 | 114 | 56 | 85 | 128 | 106 | 162 | 60 | 70 | 195 |

| dimension | flow [l/s] | | flow [l/min] | | flow [l/h] | |
|----------------|------------|-------|--------------|--------|------------|---------|
| | min. | max. | min. | max. | min. | max. |
| G½" (DN15) LF | 0.009 | 0.033 | 0.54 | 1.98 | 32.4 | 118.8 |
| G½" (DN15) SF | 0.029 | 0.146 | 1.74 | 8.76 | 104.4 | 525.6 |
| G½" (DN15) HF | 0.080 | 0.308 | 4.80 | 18.48 | 288.0 | 1108.8 |
| G¾" (DN20) SF | 0.097 | 0.264 | 5.82 | 15.84 | 349.2 | 950.4 |
| G¾" (DN20) HF | 0.229 | 0.585 | 13.74 | 35.1 | 824.4 | 2106.0 |
| G1" (DN25) SF | 0.235 | 0.589 | 14.1 | 35.34 | 846.0 | 2120.4 |
| G¾" (DN25) HF | 0.393 | 0.86 | 23.58 | 51.6 | 1414.8 | 3096.0 |
| G1¼" (DN32) HF | 0.503 | 1.159 | 30.18 | 69.54 | 1810.8 | 4172.4 |
| G1¼"(DN40) SF | 0.981 | 1.988 | 58.86 | 119.28 | 3531.6 | 7156.8 |
| G2" (DN50) HF | 1.347 | 3.168 | 80.82 | 190.08 | 4849.2 | 11404.8 |

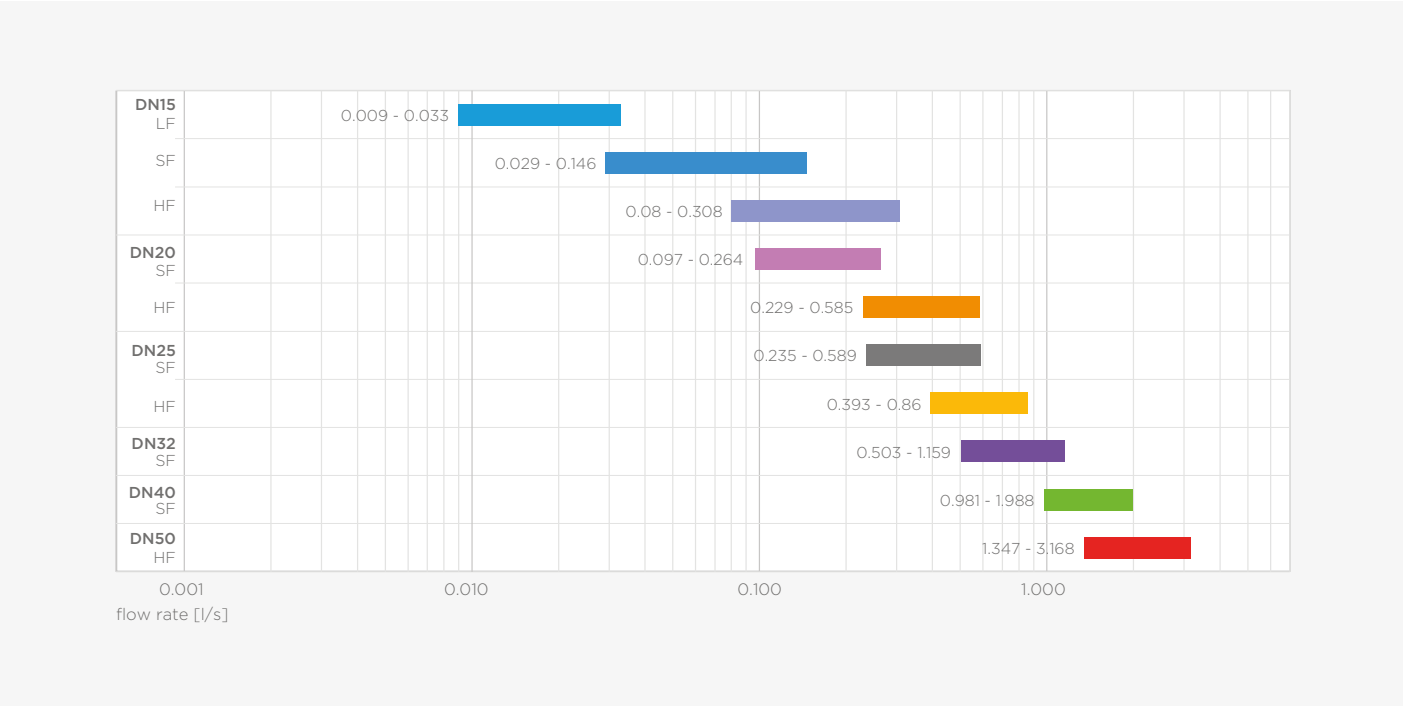

flow rate

PS1500 Pegler ProFlow pressure independent control valve
(2 x press)

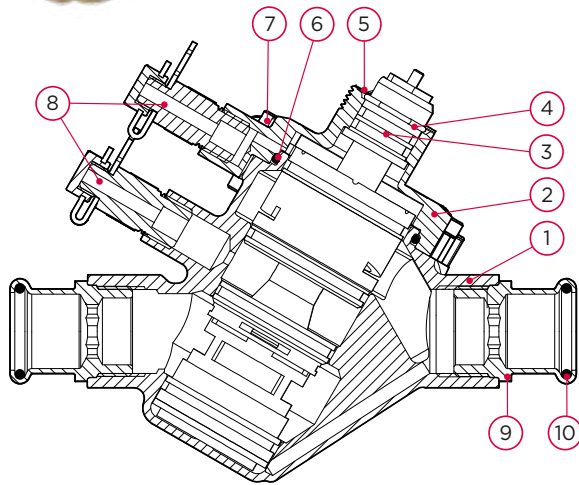

specifications

- built in direct flow measurement with venturi technology
- clear visual indicator for settings
- new Fast Flush cap for simplified access to cartridge and flushing
- VSH XPress connections for copper, carbon steel and stainless steel tube
- differential pressure control range 30-400 kPa
- on/off control characteristic

| no. | component | material |
|-----|----------------|--|
| 1 | body | DN15-25: brass (CW511L) DN32-50: brass (CC770S lead-free) |
| 2 | cap | DN15-25: brass (CW511L) DN32-50: brass (CC770S lead-free) |
| 3 | cartridge | polyphenylene sulphide (PPS) |
| 4 | spring clip | stainless steel (302526) |
| 5 | indicator | stainless steel (AISI 304) |
| 6 | o-ring | EPDM (EPI/1/5) |
| 7 | socket screw | stainless steel (A2-70) |
| 8 | test point | brass (CW602N) |
| 9 | end connection | gunmetal (EN CC491K) |
| 10 | o-ring | EPDM (EPI/1/5) |

maximum pressure [bar]

| operating pressure | test pressure shell | test pressure seat |
|--------------------|---------------------|--------------------|
| 16 | 24 | n/a |

pressure equipment directive category

| | |
|-----------|-----|
| all sizes | SEP |
|-----------|-----|

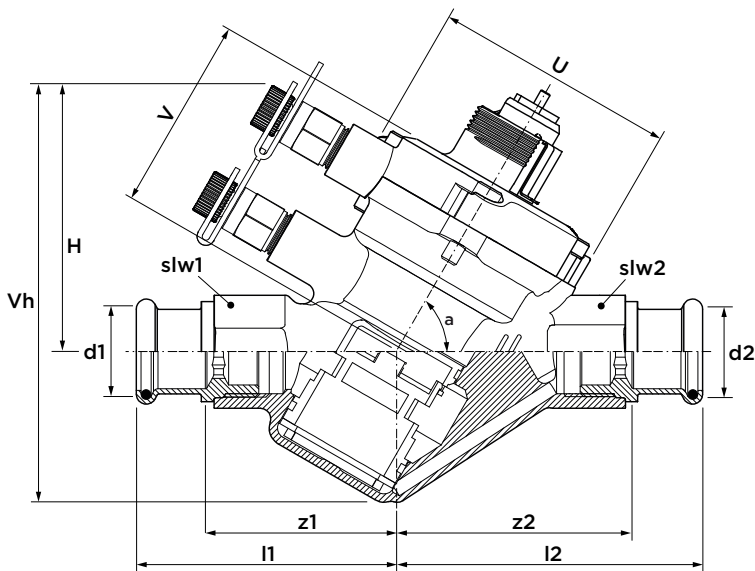

| dimension | article no. | weight [kg] | l1 | l2 | z1 | z2 | H | V | U [Ø] | a [°] | slw1/sl2 | Vh? |
|----------------|-------------|-------------|-----|-----|----|-----|-----|-----|-------|-------|----------|-----|
| G½" (DN15) LF | 15184 | 0.748 | 67 | 78 | 46 | 47 | 69 | 45 | 68 | 60 | 28 | 104 |
| G½" (DN15) SF | 15185 | 0.748 | 67 | 78 | 46 | 34 | 69 | 45 | 68 | 60 | 28 | 104 |
| G½" (DN15) HF | 15186 | 0.748 | 67 | 78 | 46 | 47 | 69 | 45 | 68 | 60 | 28 | 104 |
| G¾" (DN20) SF | 15187 | 1.186 | 70 | 90 | 70 | 56 | 78 | 57 | 81 | 60 | 34 | 122 |
| G¾" (DN20) HF | 15188 | 1.186 | 70 | 90 | 70 | 56 | 78 | 57 | 81 | 60 | 34 | 122 |
| G1" (DN25) SF | 15189 | 1.773 | 86 | 109 | 63 | 86 | 89 | 65 | 108 | 60 | 41 | 132 |
| G¾" (DN25) HF | 15199 | 1.773 | 86 | 109 | 63 | 86 | 89 | 65 | 108 | 60 | 41 | 132 |
| G1¼" (DN32) HF | 15200 | 2.381 | 98 | 119 | 71 | 93 | 102 | 77 | 124 | 60 | 50 | 156 |
| G1¼" (DN40) SF | 15274 | 4.038 | 114 | 148 | 84 | 118 | 129 | 107 | 162 | 60 | 57 | 195 |
| G2" (DN50) HF | 15275 | 4.775 | 129 | 157 | 94 | 122 | 128 | 106 | 162 | 60 | 70 | 195 |

| dimension | flow [l/s] | | flow [l/min] | | flow [l/h] | |
|----------------|------------|-------|--------------|--------|------------|---------|
| | min. | max. | min. | max. | min. | max. |
| G½" (DN15) LF | 0.009 | 0.033 | 0.54 | 1.98 | 32.4 | 118.8 |
| G½" (DN15) SF | 0.029 | 0.146 | 1.74 | 8.76 | 104.4 | 525.6 |
| G½" (DN15) HF | 0.080 | 0.308 | 4.80 | 18.48 | 288.0 | 1108.8 |
| G¾" (DN20) SF | 0.097 | 0.264 | 5.82 | 15.84 | 349.2 | 950.4 |
| G¾" (DN20) HF | 0.229 | 0.585 | 13.74 | 35.1 | 824.4 | 2106.0 |
| G1" (DN25) SF | 0.235 | 0.589 | 14.1 | 35.34 | 846.0 | 2120.4 |
| G¾" (DN25) HF | 0.393 | 0.86 | 23.58 | 51.6 | 1414.8 | 3096.0 |
| G1¼" (DN32) HF | 0.503 | 1.159 | 30.18 | 69.54 | 1810.8 | 4172.4 |
| G1¼"(DN40) SF | 0.981 | 1.988 | 58.86 | 119.28 | 3531.6 | 7156.8 |
| G2" (DN50) HF | 1.347 | 3.168 | 80.82 | 190.08 | 4849.2 | 11404.8 |

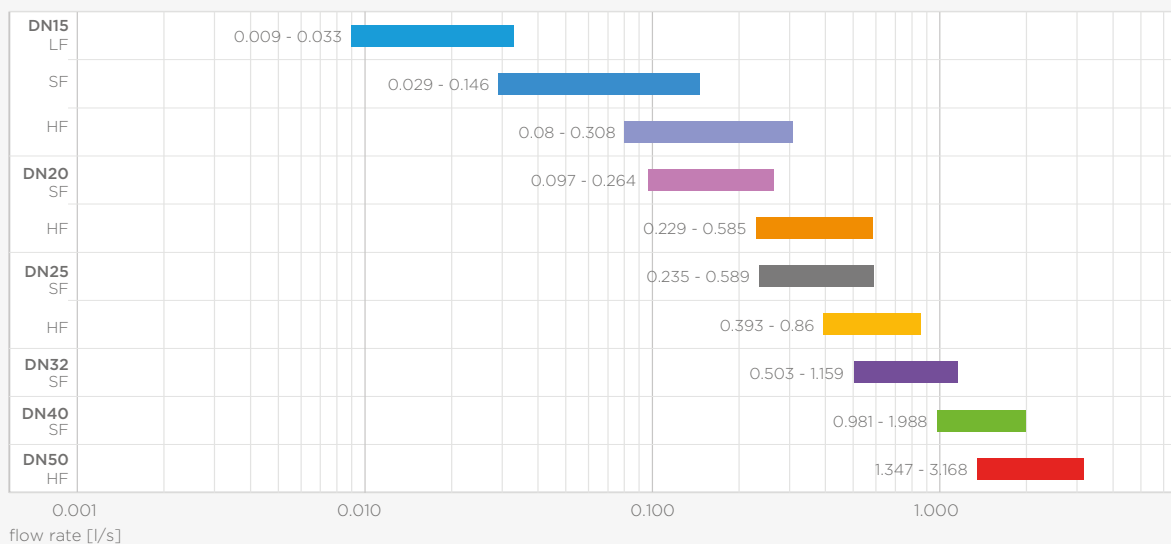

flow rate

PSU1500 Pegler ProFlow pressure independent control valve

(2 x press, with union connection, outlet)



specifications

- built in direct flow measurement with venturi technology
- clear visual indicator for settings
- new Fast Flush cap for simplified access to cartridge and flushing
- VSH XPress connections for copper, carbon steel and stainless steel tube
- differential pressure control range 30-400 kPa
- on/off control characteristic

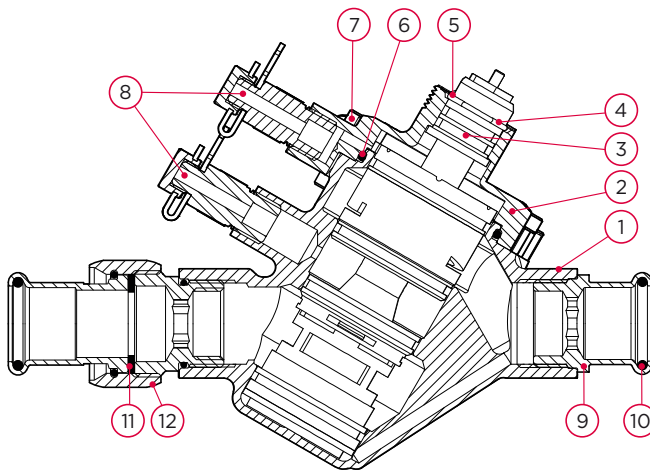

| no. | component | material |
|-----|----------------|--|
| 1 | body | DN15-25: brass (CW511L) DN32-50: brass (CC770S lead-free) |
| 2 | cap | DN15-25: brass (CW511L) DN32-50: brass (CC770S lead-free) |
| 3 | cartridge | polyphenylene sulphide (PPS) |
| 4 | spring clip | stainless steel (302526) |
| 5 | indicator | stainless steel (AISI 304) |
| 6 | o-ring | EPDM (EP1/1/5) |
| 7 | socket screw | stainless steel (A2-70) |
| 8 | test point | brass (CW602N) |
| 9 | end connection | gunmetal (EN CC491K) |
| 10 | o-ring | EPDM (EP1/1/5) |
| 11 | flat seal | fibre |
| 12 | union nut | brass (CW602N) |

maximum pressure [bar]

| operating pressure | test pressure shell | test pressure seat |
|--------------------|---------------------|--------------------|
| 16 | 24 | n/a |

pressure equipment directive category

| | |
|-----------|-----|
| all sizes | SEP |
|-----------|-----|

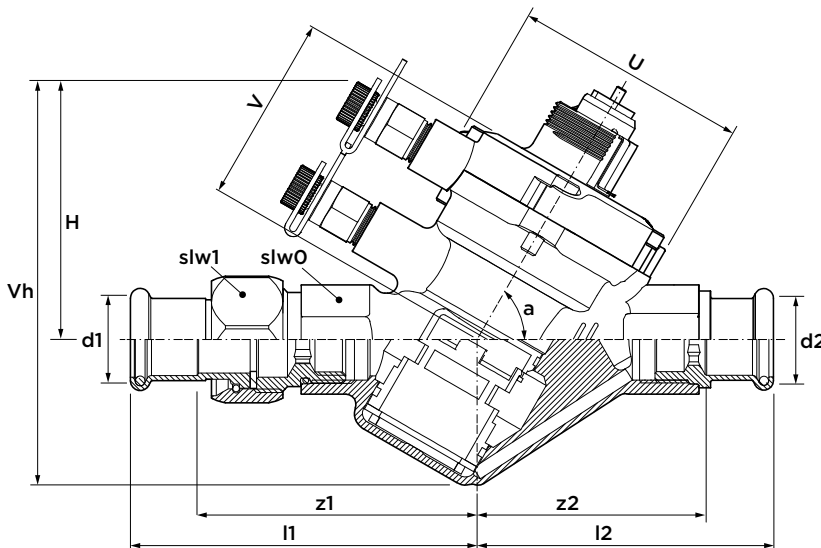

| dimension | article no. | weight [kg] | l1 | l2 | z1 | z2 | H | V | U [Ø] | a [°] | slw0 | slw1 | Vh |
|----------------|-------------|-------------|-----|-----|----|-----|-----|-----|-------|-------|------|------|-----|
| G½" (DN15) LF | 15459 | 0.834 | 67 | 100 | 46 | 80 | 69 | 45 | 68 | 60 | 28 | 30 | 104 |
| G½" (DN15) SF | 15461 | 0.834 | 67 | 100 | 46 | 80 | 69 | 45 | 68 | 60 | 28 | 30 | 104 |
| G½" (DN15) HF | 15463 | 0.834 | 67 | 100 | 46 | 80 | 69 | 45 | 68 | 60 | 28 | 30 | 104 |
| G¾" (DN20) SF | 15464 | 1.315 | 70 | 119 | 70 | 99 | 78 | 57 | 81 | 60 | 34 | 36 | 122 |
| G¾" (DN20) HF | 15466 | 1.315 | 70 | 119 | 70 | 99 | 78 | 57 | 81 | 60 | 34 | 36 | 122 |
| G1" (DN25) SF | 15467 | 1.953 | 86 | 134 | 63 | 111 | 89 | 65 | 108 | 60 | 41 | 46 | 132 |
| G¾" (DN25) HF | 15469 | 1.953 | 86 | 134 | 63 | 111 | 89 | 65 | 108 | 60 | 41 | 46 | 132 |
| G1¼" (DN32) HF | 15479 | 2.619 | 98 | 145 | 71 | 119 | 102 | 77 | 124 | 60 | 50 | 52 | 156 |
| G1¼" (DN40) SF | 15488 | 4.315 | 114 | 175 | 84 | 146 | 129 | 107 | 162 | 60 | 57 | 58 | 195 |
| G2" (DN50) HF | 15489 | 5.216 | 129 | 186 | 94 | 152 | 128 | 106 | 162 | 60 | 70 | 75 | 195 |

| dimension | flow [l/s] | | flow [l/min] | | flow [l/h] | |
|----------------|------------|-------|--------------|--------|------------|---------|
| | min. | max. | min. | max. | min. | max. |
| G½" (DN15) LF | 0.009 | 0.033 | 0.54 | 1.98 | 32.4 | 118.8 |
| G½" (DN15) SF | 0.029 | 0.146 | 1.74 | 8.76 | 104.4 | 525.6 |
| G½" (DN15) HF | 0.080 | 0.308 | 4.80 | 18.48 | 288.0 | 1108.8 |
| G¾" (DN20) SF | 0.097 | 0.264 | 5.82 | 15.84 | 349.2 | 950.4 |
| G¾" (DN20) HF | 0.229 | 0.585 | 13.74 | 35.1 | 824.4 | 2106.0 |
| G1" (DN25) SF | 0.235 | 0.589 | 14.1 | 35.34 | 846.0 | 2120.4 |
| G¾" (DN25) HF | 0.393 | 0.86 | 23.58 | 51.6 | 1414.8 | 3096.0 |
| G1¼" (DN32) HF | 0.503 | 1.159 | 30.18 | 69.54 | 1810.8 | 4172.4 |
| G1¼"(DN40) SF | 0.981 | 1.988 | 58.86 | 119.28 | 3531.6 | 7156.8 |
| G2" (DN50) HF | 1.347 | 3.168 | 80.82 | 190.08 | 4849.2 | 11404.8 |

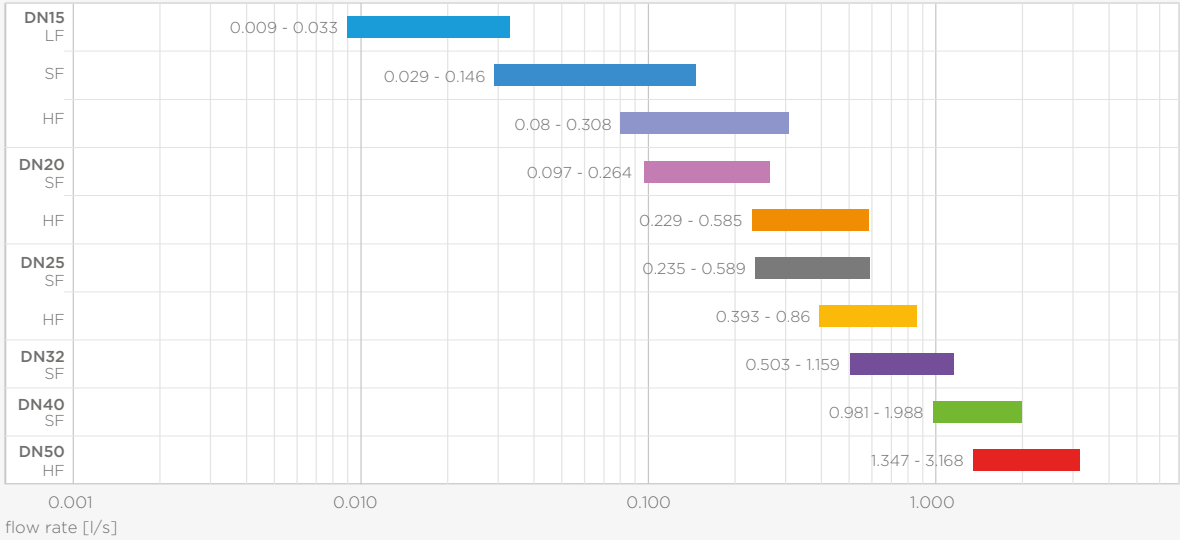

flow rate Pegler



Pegler ProFlow

tools and
accessories

ProFlow

AT01 electro thermal actuator (open/closed)



specifications

- compact dimensions
- first-open function
- maintenance free
- noiseless
- low power consumption
- 360° installation position
- fire resistance to UL94V-0
- position indicator

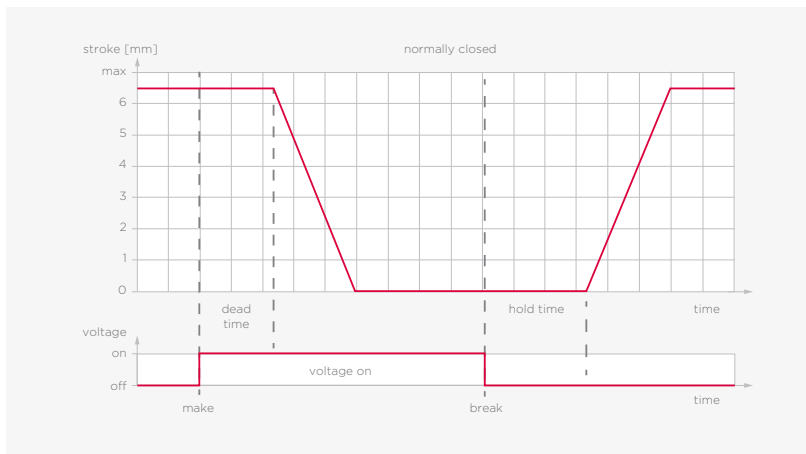
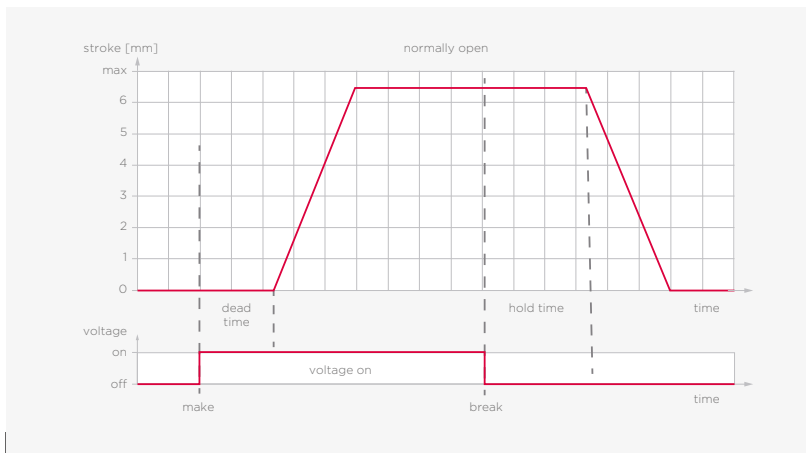

| specifications | On/Off actuator 24V | On/Off actuator 230V |
|---|--|---------------------------------------|
| operating voltage | 24V AC/DC -10 % to +20 % | 230V AC -10 % to +10 % |
| operating power | 2.3V A 1W | 3.6V A 1W |
| actuator stroke | 4 mm | 4 mm |
| stroke time | approx. 3.5 min/ 4 min/5 min | approx. 3.5 min/ 4 min/5 min |
| actuating force | 100/125N | 100/125N |
| ambient temperature - fluid temperature - storage | 0 to 60°C 0 to 100°C -25 to 60°C | 0 to 60°C 0 to 50°C -25 to 60°C |
| protection class | IP54 | IP54 |
| connecting cable | 1 m, 2 core | 1 m, 2 core |
| housing | plastic | plastic |
| CE conformity | EN 60730-1 | EN 60730-1 |

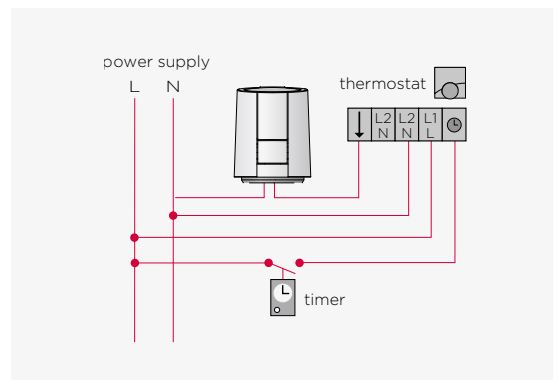

In the example above the actuator is connected to a power supply of 24V AC, 24V DC or 230V AC. In case the thermostat switch is activated and the actuator being in the normally closed version, the valve is opened steadily by the plunger motion. In the normally open version the valve is closed.

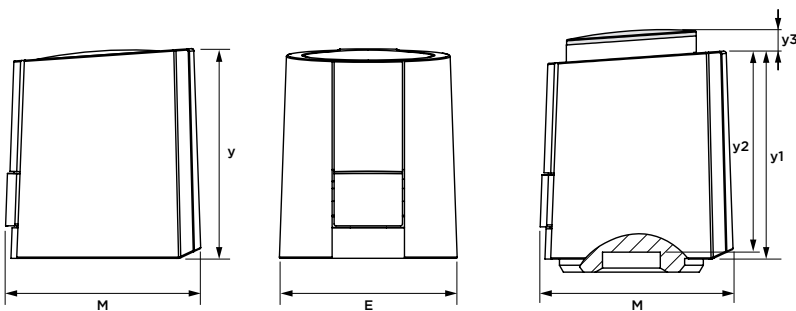

| actuator type | article no. | voltage | weight [kg] | E | M | y1 | y2 | y3 |
|------------------------------------|-------------|-----------|-------------|----|----|----|----|----|
| DN15 - DN32 (normally closed - NC) | 15202 | 24V AC/DC | 0.14 | 44 | 48 | 52 | 50 | 7 |
| DN15 - DN32 (normally closed - NC) | 15280 | 230V AC | 0.14 | 44 | 48 | 52 | 50 | 7 |

AE01 electro thermal actuator
(proportional control, normally closed)

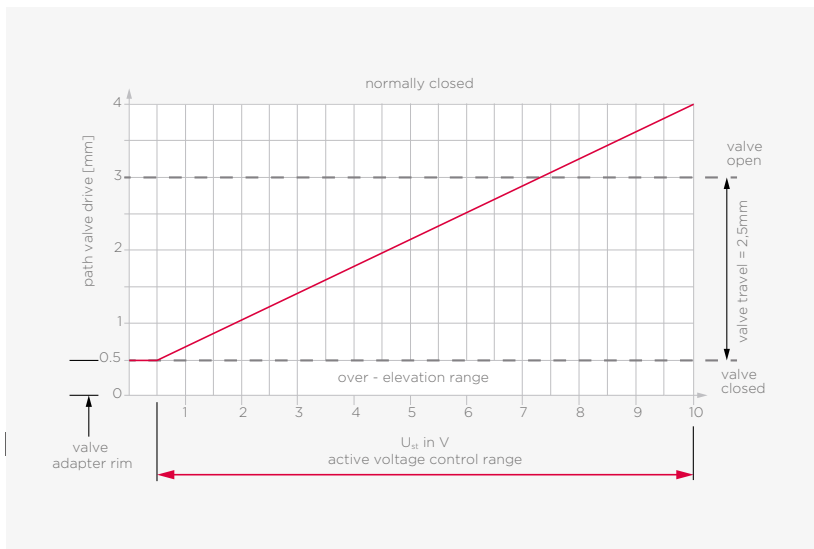

specifications

- proportional actuator
- compact dimensions
- first-open function
- maintenance free
- noiseless
- low power consumption
- 360° installation position
- fire resistance to UL94V-0

| specifications | modulating actuator 24V |
|---------------------|------------------------------------|
| operating voltage | 24V AC |
| operating power | 3.1V A |
| actuator stroke | 4 mm |
| stroke time | approx. 3.5 min/4 min/5 min |
| actuating force | 100/125N |
| ambient temperature | 0 to 60°C |
| - fluid temperature | 0 to 50°C |
| - storage | -25 to 60°C |
| protection class | IP54 |
| ambient humidity | 0 - 95% |
| connecting cable | colour-coded fly lead, 1 m, 3 core |
| housing | plastic |
| CE conformity | EN 60730-1 |

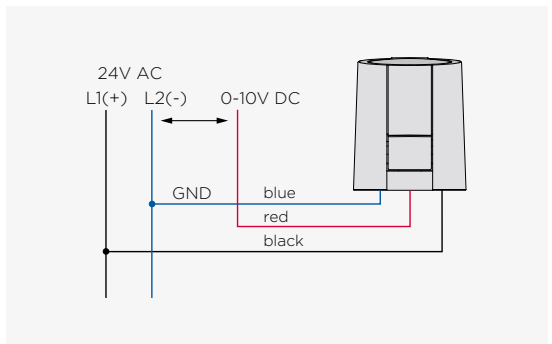

The above example is connected to a 24V AC or 24V DC power supply, with a control voltage from 0-10V-DC. When the control voltage is increased, the electronic control system immediately adapts the heat input to the elastic element and the valve is further opened, with the valve being normally closed (0 Volt).

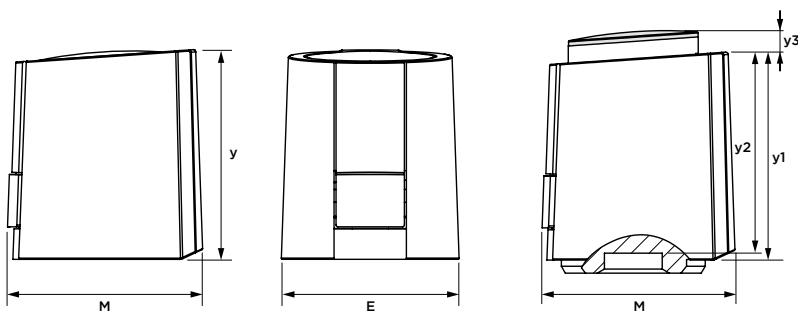

| actuator type | article no. | voltage | weight [kg] | E | M | y1 | y2 | y3 |
|----------------------------------|-------------|-----------------|-------------|----|----|----|----|----|
| DN15 - 32 (normally closed - NC) | 15281 | 24V AC (10V DC) | 0.14 | 44 | 48 | 52 | 50 | 7 |

AP02 electro motoric actuator modulating

(proportional control, normally open)



specifications

- fast acting
- double colour LED
- removable cable
- direct acting

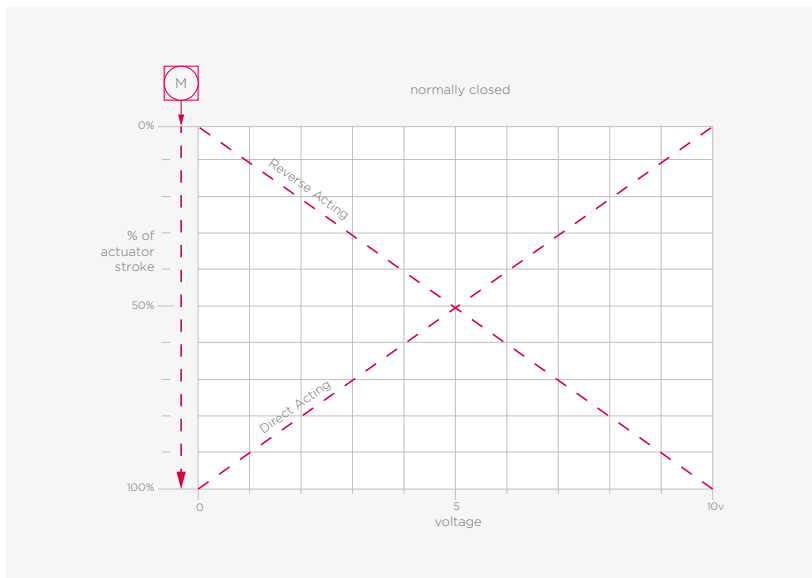

DIP switch 4 sets whether the actuator is 'Direct Acting' or 'Reverse Acting'

| specifications | modulating floating 24V |
|---------------------|-----------------------------------|
| operating voltage | 24V AC +/-10% |
| operating power | 2.5V A |
| actuator stroke | 3.2 mm |
| stroke time | 8 sec/mm |
| actuating force | 120N |
| ambient temperature | 0 - 60°C |
| -operating | 0 - 50°C |
| -storage | -20 - 65°C |
| protection class | IP43 |
| ambient humidity | 0 - 95% |
| connecting cable | 1.5 m (3 x 0.35 mm ²) |
| housing | ABS + PC |
| CE conformity | EN 60730-1 |

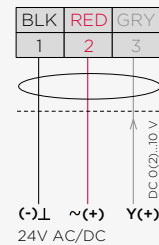

24V AC/DC proportional model

When the power is applied, the actuator self-calibrates performing an auto zero detection cycle. The actuator moves the stem down for a complete mechanical valve stroke until no changes are detected. Once the auto-zero is detected the actuator moves the stem accordingly with the input signal, within the value of the electrical stroke as per jumper setting.

When the input signal increases (eg. from 0V to 10V) the actuator stem extends if the actuator is configured as Direct Action (DA).

When the input signal decreases (eg. from 10V to 0V) the actuator stem retracts if the actuator is configured as Direct Action (DA).

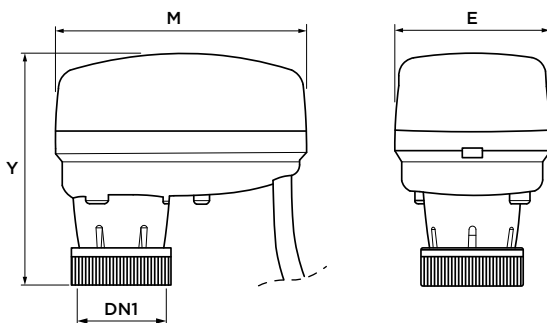

| actuator type | article no. | voltage | weight [kg] | DNI | E | M | Y |
|----------------------------------|-------------|-------------------|-------------|-----------|----|----|----|
| DN15 - DN25 (normally open - NO) | 18275 | 24V AC (0-10V DC) | 0.2 | M30 x 1.5 | 49 | 80 | 74 |

AP01 electro motoric actuator
(proportional control with feedback, normally open)



specifications

- fast acting
- double colour LED
- removable cable
- self adapting
- includes feedback
- Factory setting: 'Reverse Acting'

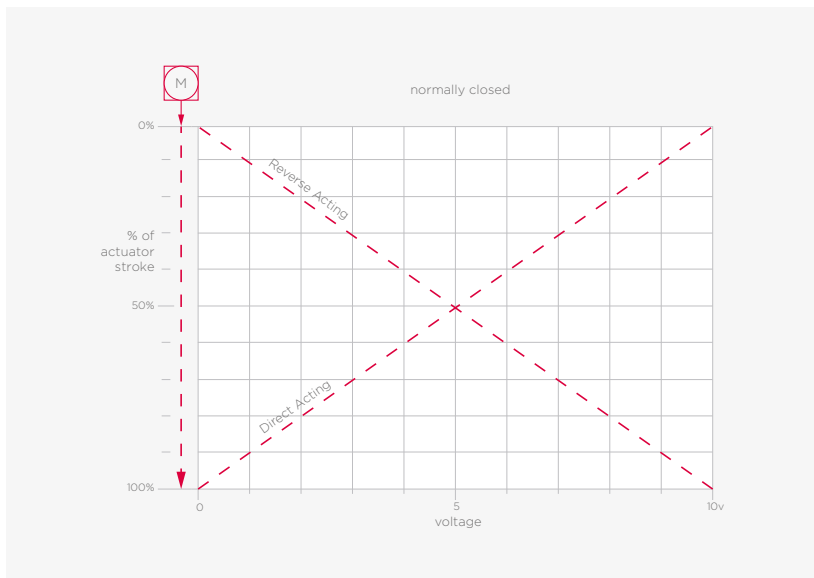

DIP switch 4 sets whether the actuator is 'Direct Acting' or 'Reverse Acting'

| specifications | proportional actuator 24V |
|---------------------|---------------------------------|
| operating voltage | 24V AC |
| operating power | 6.0V A |
| actuator stroke | 6.3 mm self adapting |
| stroke time | 8 sec/mm |
| actuating force | 160N |
| ambient temperature | 0 - 60°C |
| -operating | 0 - 50°C |
| -storage | -20 - 65°C |
| protection class | IP54 |
| ambient humidity | 0 - 95% |
| connecting cable | 2 m (4 x 0.35 mm ²) |
| housing | ABS + PC |
| CE conformity | EN 60730-1 |

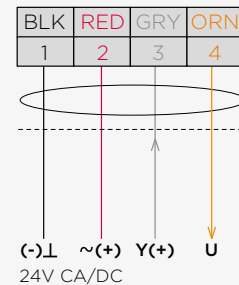

When the power is applied, the actuator self-calibrates performing an auto zero detection cycle. The actuator moves the stem down for a complete mechanical valve stroke until no changes are detected. Once the auto-zero is detected the actuator moves the stem accordingly with the input signal, within the value of the electrical stroke as per jumper setting.

When the input signal increases (eg. from 0V to 10V) the actuator stem retracts if the actuator is configured as Reverse Action (RA).

When the input signal decreases (eg. from 10V to 0V) the actuator stem extends if the actuator is configured as Reverse Action (RA).

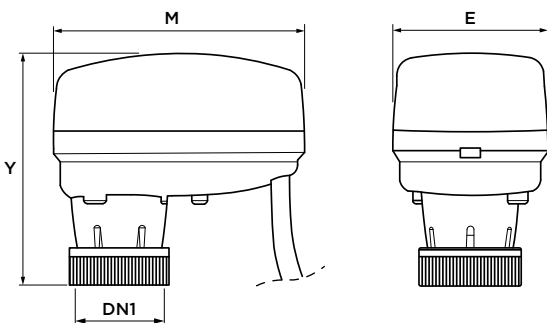

| valve type | article no. | voltage | weight [kg] | DN1 | E | M | Y |
|----------------------------------|-------------|-------------------|-------------|-----------|----|----|----|
| DN15 - DN25 (normally open - NO) | 18276 | 24V AC (0-10V DC) | 0.2 | M30 x 1.5 | 49 | 80 | 74 |

15208 AVUE motoric actuator

(DN40 - 50)



specifications

- AVUE actuators: proportional or increase/decrease control
- PC board with 2 micro-switches for position detection
- IP43 protection class
- manual override with a 3 mm Allen Key
- proportional actuators compatible with various signals
- feedback signal: 2 - 10V DC (2V = fully retracted, 10V = fully extended)
- LED identification for status and command
- actuator movement direction selected via dip-switch

| specification | proportional actuator 24V |
|---------------------|---------------------------|
| operating voltage | 24V AC |
| operating power | 3.6V A |
| control voltage | 0-10V DC |
| actuator stroke | 6.3 mm |
| stroke time | 11.5 s/mm |
| actuating force | 300N |
| ambient temperature | |
| - operating | -5.55°C |
| - storage | -25 - 65°C |
| protection class | IP43 |
| ambient humidity | 0-95% |
| connecting cable | 1.5 m long, 5 core |
| CE conformity | EN 60730-1 |

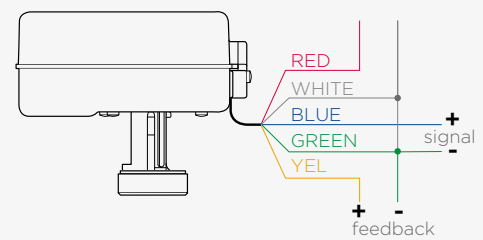

modulating

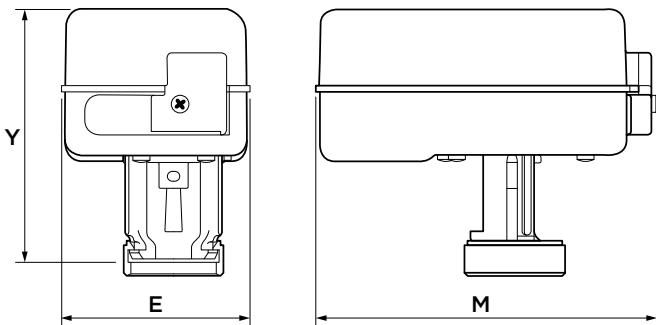

| actuator type | article no. | voltage | weight [kg] | E | M | Y |
|-------------------------------|-------------|-------------------|-------------|----|-----|----|
| DN 40- 50 modulating actuator | 15207 | 24V AC (0-10V DC) | 0.25 | 62 | 112 | 82 |

BC3 Pegler ProFlow balancing computer



specifications

- digital compensation of temperature effects
- user app for Android / iOS mobile devices
- correction of antifreeze flow calculation
- easy selection of balancing valve according to valve illustration
- capability of saving up to 2000 measured valves
- cover IP65 rated

Verification of flow can be done using a suitable flow measurement device and utilising the built-in test points on the valve.

The Pegler ProFlow BC3 balancing computer is supplied pre-programmed with the loss coefficient data (k values) allowing a direct measurement of flow rate to be obtained ensuring the system is balanced correctly to achieve optimum efficiency.



To download app search for Pegler BC3



App requires Pegler ProFlow BC3 balancing computer

product specification

| | |
|-------------------------------------|---|
| wireless data transfer | Bluetooth low energy 5.0 |
| power supply | AAA Alkaline batteries or NiMH rechargeable batteries |
| power consumption | 25 mA |
| operating time | 45 h Max |
| zeroing of the pressure measurement | mechanical with hydraulic bypass |
| water resistance | IP65 |
| calibration validity | 24 months |

maximum pressure conditions

| | |
|---|--|
| normal pressure range | 1.000 kPa |
| max. over pressure | 120% of nominal pressure |
| linearity and hysteresis error | 0.15% from nominal pressure range |
| error for the pressure range 0 till 5 kPa after pressure zero setting | ± 50 Pa for nominal pressure range 1 MPa |
| temperature error | 0.25 % from nominal pressure range |
| medium temperature** | -5 - 90°C |
| ambient temperature | -5 - 50°C |
| storage temperature | -5 - 50°C |

** measured at the end of measuring hoses, length 1.5 m. Hot water flows through BC3 ProFlow Technics hydraulic parts during pressure zero procedure. Maximum time duration of zeroing when temperature of the medium exceeds 50°C is 10 seconds.

| article no. | description | weight [kg] | length [mm] | width [mm] | height [mm] |
|-------------|--------------------|-------------|-------------|------------|-------------|
| 16395 | Pegler ProFlow BC3 | 0.420 | 180 | 80 | 52 |

1600SSP setting key
(for Pegler ProFlow 1600 PICV)



| dimension | article no. |
|-------------|-------------|
| DN15 - DN25 | 16075 |

*see installation guidelines Pegler ProFlow 1600 PICV, page 22

1600PT operating tool
(for Pegler ProFlow 1600 PICV)



| dimension | article no. |
|-------------|-------------|
| DN15 | 16079 |
| DN20 - DN25 | 16080 |

*see installation guidelines Pegler ProFlow 1600 PICV, page 22

1600LPT locking pin and tether
(for Pegler ProFlow 1600 PICV)



| dimension | article no. |
|-------------|-------------|
| DN15 | 16076 |
| DN20 - DN25 | 16077 |

1600CRT cartridge
(for Pegler ProFlow 1600 PICV)



| dimension | article no. | colour |
|-------------------------------------|-------------|--------|
| DN15 low flow | 16070 | white |
| DN15 standard flow | 16071 | red |
| DN15 high flow | 16072 | black |
| DN20 standard flow | 16073 | white |
| DN20 high flow / DN25 standard flow | 16074 | black |

1500CRT cartridge
(for Pegler ProFlow 1500 PICV)



| dimension | article no. | colour |
|--------------------|-------------|--------|
| DN15 low flow | 16081 | white |
| DN15 standard flow | 16082 | red |
| DN15 high flow | 16083 | black |
| DN20 standard flow | 16084 | white |
| DN25 standard flow | 16085 | black |
| DN25 high flow | 16086 | black |
| DN32 standard flow | 16087 | black |
| DN40 standard flow | 16088 | black |
| DN50 high flow | 16089 | black |

1500FLC setting and flushing cap
(for Pegler ProFlow 1500 PICV)



| dimension | article no. |
|-----------|-------------|
| DN15 | 16090 |
| DN20 | 16091 |
| DN25 | 16092 |

1500FLP setting and flushing plug
(for Pegler ProFlow 1500 PICV)



| dimension | article no. |
|-----------|-------------|
| DN30-50 | 16093 |

disclaimer:

The technical data are non-binding and do not reflect the warranted characteristics of the products. They are subject to change. Please consult our General Terms and Conditions. Additional information is available upon request. It is the designer's responsibility to select products suitable for the intended purpose and to ensure that pressure ratings and performance data are not exceeded. The installation instructions should always be read and followed. The system must always be depressurized and drained before any components, whether defective or otherwise, are removed, modified or corrected.

more information?

For a complete and up-to-date product range and our additional services, visit: www.aalberts-ips.co.uk



Would you like to make an appointment to meet an account manager in your region or receive advice and support from one of our experts? Please scan the QR code or contact:

Aalberts integrated piping systems Ltd

tel: +44 (0) 1302 560 560

email: info.uk@aalberts-ips.com

*All brand names and logo styles are registered trademarks.
Maintaining a policy in this publication without prior notice.*

